

26626 26627

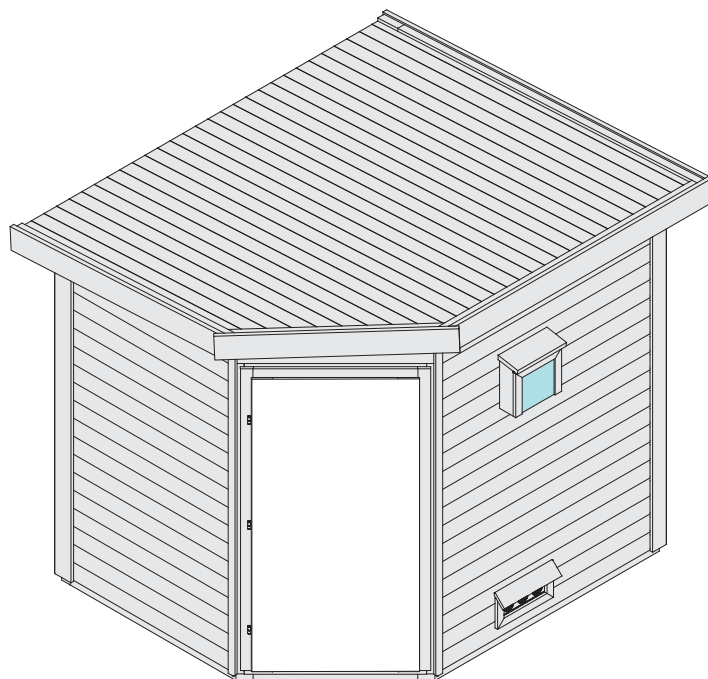

-  **Aufbauanleitung**
-  **Building Instructions**
-  **notice de montage**
-  **montagehandleiding**
-  **Montagevejledning**
-  **Instrucciones de construcción**
-  **Istruzioni per il montaggio**
-  **Montážní návod**

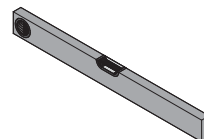
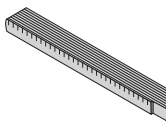
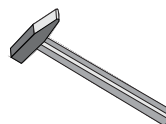
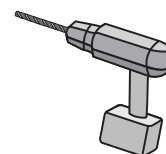
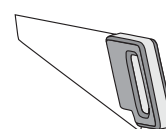

Bitte bewahren Sie die Anleitung und den Garantieschein zur Seriennummer auf.

Vernichten Sie diese erst nach Ablauf der Garantiezeit.

Eventuelle Beanstandungen können mithilfe der Stückliste einfacher zugeordnet werden.

Beigelegte Dokumente

- Informationsheft
- Garantieschein zur Seriennummer
- Typenschild inkl. Warnhinweise (Sauna)
- ggf. Zubehör-Anleitungen in externen Paketen

- | | |
|---|---|
| <p>*</p> <p> Nicht im Lieferumfang enthalten</p> <p> Not included</p> <p> Non comprises dans la livraison</p> <p> Niet bijgeleverd</p> | <p> No forman parte del suministro</p> <p> Non incluso</p> <p> V ceně není zahrnuto</p> <p> Ikke inkluderet</p> |
| <p>1</p> <p> Länge muss ermittelt und zugesägt werden</p> <p> Length must be determined and sawn</p> <p> La longueur doit être déterminée et sciée</p> <p> De lengte moet worden bepaald en worden gezaagd</p> | <p> La longitud debe ser determinada y aserrada</p> <p> La lunghezza deve essere determinata e segata</p> <p> Délka musí být určena a rozřezána</p> <p> Længden skal bestemmes og saves</p> |
| <p>2</p> <p> Nicht gebraucht</p> <p> Not needed</p> <p> Pas nécessaire</p> <p> Niet nodig</p> | <p> No es necesario</p> <p> Non necessario</p> <p> Není nutná</p> <p> Ikke nødvendigt</p> |
| <p>3</p> <p> Mit Zubehör</p> <p> With accessories</p> <p> Avec accessoires</p> <p> Met toebehoren</p> | <p> Con accesorios</p> <p> Con accessori</p> <p> S příslušenstvím</p> <p> Med tilbehør</p> |
| <p>4</p> <p> Fixiert vorübergehend</p> <p> Fixed temporarily</p> <p> Temporairement fixe</p> <p> Tijdelijk vast</p> | <p> Temporalmente fijo</p> <p> Temporaneamente fisso</p> <p> Dočasně pevný</p> <p> Midlertidigt rettet</p> |
| <p>5</p> <p> Bestand vom Haus</p> <p> Inventory of the house</p> <p> Inventaire de la maison</p> <p> Inventaris van het huis</p> | <p> Inventario de la casa</p> <p> Inventario della casa</p> <p> Inventář domu</p> <p> Inventar af huset</p> |

Werkzeuge / Tools*

X

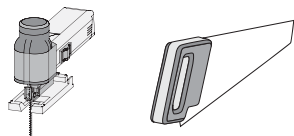

X

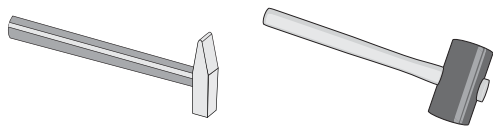

X

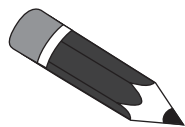

X

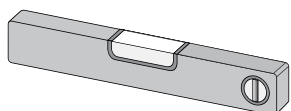

X

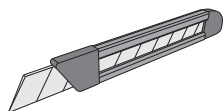

X

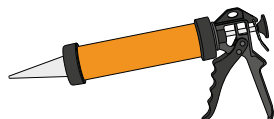
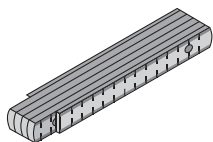

X

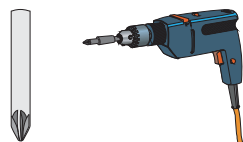

X

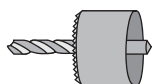
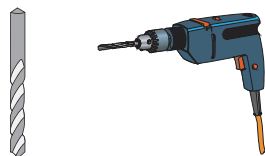

X

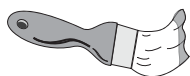

X



Technische Daten

In der Auftragsbestätigung bzw. Lieferschein ist der gekaufte Ofentyp bzw. das erworbene Steuergerät zu finden. Bitte entnehmen Sie die technischen Daten Ihrer Geräte der folgenden Auflistung

Gerät	Netzspannung	Wattage
Öfen		
9kW Ofen Bio	400V ~ 3N	9kW
9kW Ofen (Finnisch)	400V ~ 3N	9kW
9kW Ofen integr. Steuerung	400V ~ 3N	9kW
4,5kW Ofen Bio	400V ~ 3N	4,5kW
4,5kW Ofen (Finnisch)	400V ~ 3N	4,5kW
4,5kW Ofen integr. Steuerung	400V ~ 3N	4,5kW
3,6kW Ofen Bio	230V ~ 1N	3,6kW
3,6kW Ofen (Finnisch)	230V ~ 1N	3,6kW
3,6kW Ofen integr. Steuerung	230V ~ 1N	3,6kW
Steuergeräte		
externe Steuerung Easy Bio	400V ~ 3N	max. 10,8kW
externe Steuerung Plug&Play Bio	240V ~ 3N	max. 10,8kW
externe Steuerung (Finnisch)	400V ~ 3N	max. 10,8kW
externe Steuerung Plug&Play (Finnisch)	240V ~ 3N	max. 10,8kW
Multisteuergerät	400V ~ 3N	max. 10,5kW
externe Steuerung Classic Bio	400V ~ 3N	max. 9kW
externe Steuerung Classic (Finnisch)	400V ~ 3N	max. 9kW
externe Steuerung Premium Bio	400V ~ 3N	max. 12kW
externe Steuerung Premium (Finnisch)	400V ~ 3N	max. 9kW



Vergleichen Sie zuerst die Material-liste mit Ihrem Paketinhalt! Bitte haben Sie Verständnis, dass Beanstandungen nur im nicht aufgebauten Zustand bearbeitet werden können!



Vergelijk eerst de lijst van materialen met de inhoud van uw pakket! Reclamaties kunnen alleen in behandeling worden genomen zolang de onderdelen nog niet zijn gemonteerd!



Confrontate questa distinta materiali prima con il contenuto del pacchetto! Vi preghiamo di comprendere che eventuali reclami possono essere accolti solo prima del montaggio!



First compare the list of materials with your package contents! Please understand that complaints can be processed in the non-built status only!



Start med at kontrollere materialelisten med indholdet af den leverede pakke! Vi gør venligst opmærksom på at reklamationer kun kan behandles for materialer som ikke er blevet bearbejdet!



Nejprve přezkontrolujte obsah balení podle materiálového listu! Mějte pochopení pro to, že případnou reklamaci se můžeme zabývat pouze tehdy, když díly nebudou smontované! Za pomoci tohoto seznamu můžete jednotlivé díly přiřadit k montážnímu návodu.



Commencez par comparer la liste du matériel avec le contenu de votre paquet! Sachez que nous traitons uniquement les réclamations concernant le matériel à l'état non monté!



En primer lugar, compare la lista de material con el contenido del paquete. Rogamos entienda que las reclamaciones sólo pueden ser tramitadas antes de montar el objeto!

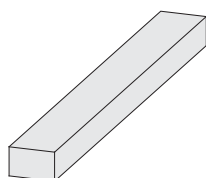
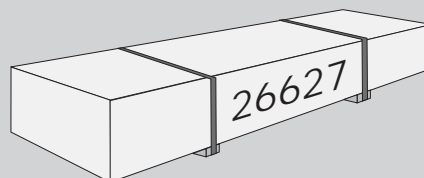
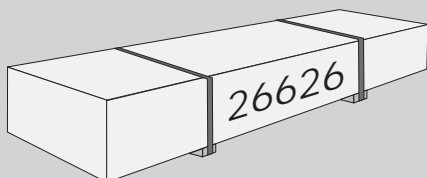

2 x B1	1920 x 20 x 3 mm	ID 20799
2 x B2	1608 x 90 x 16 mm	ID 72097
1 x B3	2156 x 90 x 16 mm	ID 71514
2 x B4	800 x 45 x 18 mm	ID 24796
2 x B5	906 x 45 x 18 mm	ID 27383
5 x B6	2100 x 45 x 18 mm	ID 19547
1 x B7	300 x 95 x 18 mm	ID 19130
4 x B8	480 x 95 x 18 mm	ID 20930
4 x B9	565 x 95 x 18 mm	ID 15498
6 x B10	2300 x 95 x 18 mm	ID 16177
1 x B11	1210 x 140 x 26 mm	ID 36420
1 x B12	2250 x 140 x 26 mm	ID 50192
4 x B13	2110 x 38 x 28 mm	ID 61719
2 x B14	800 x 58 x 28 mm	ID 15493
1 x B15	946 x 58 x 28 mm	ID 21156
2 x B16	1853 x 45 x 38 mm	ID 27380
3 x B17	1890 x 60 x 40 mm	ID 28536
1 x B18	2260 x 60 x 40 mm	ID 70614
3 x B19	2160 x 45 x 45 mm	ID 59218

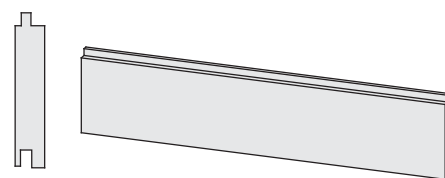

21 x R1	2195 x 96 x 19 mm	ID 65729
30 x R2	2240 x 96 x 19 mm	ID 42283

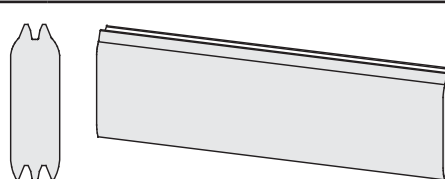

1 x W1	424 x 121 x 40 mm	ID 48175
1 x W2	791 x 121 x 40 mm	ID 42396
3 x W3	996 x 121 x 40 mm	ID 27374
18 x W4	1141 x 121 x 40 mm	ID 27371
19 x W5	1491 x 121 x 40 mm	ID 27373
18 x W6	1845 x 121 x 40 mm	ID 70465
18 x W7	2195 x 121 x 40 mm	ID 70501

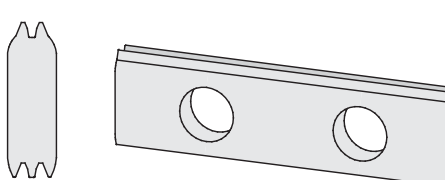

1 x W8	2195 x 121 x 40 mm	ID 4164
--------	--------------------	---------

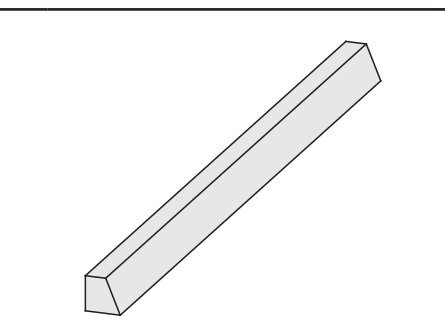

2 x F1	2175 x 38 x 25 mm	ID 27378
2 x F2	2175 x 38 x 45 mm	ID 27377

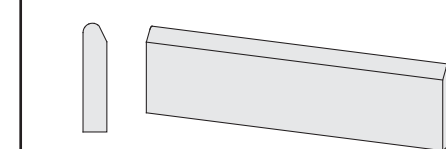

2 x F3	2250 x 45 x 17 mm	ID 27382
2 x F4	2250 x 58 x 17 mm	ID 27536

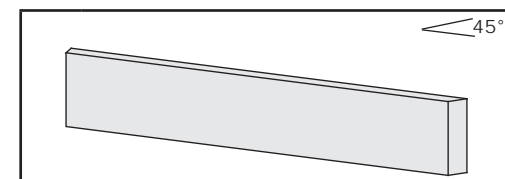

1 x A1	1470 x 140 x 26 mm	ID 70397
1 x A2	1820 x 140 x 26 mm	ID 70399

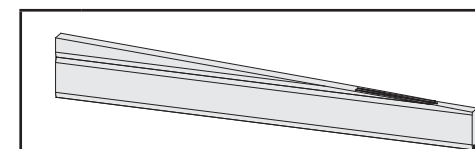

1 x G1	1141 x 162 x 40 mm	ID 27370
1 x G2	1845 x 200 x 40 mm	ID 27372

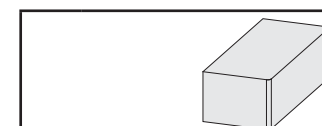

4 x K1	60 x 36 x 36 mm	ID 5512
--------	-----------------	---------

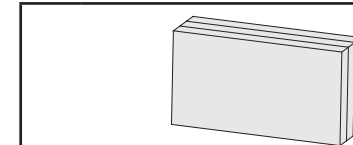

4 x P1	150 x 95 x 54 mm	ID 63278
2 x P2	2193 x 95 x 54 mm	ID 70617

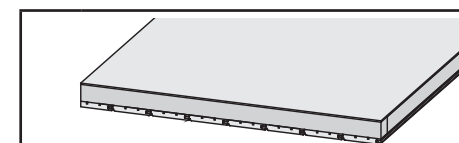

1 x N1	1839 x 350 x 57 mm	ID 53731
1 x N2	1839 x 918 x 57 mm	ID 5986

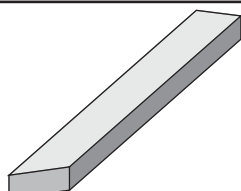

1 x C1	1216 x 60 x 40 mm	ID 70403
1 x C2	1626 x 60 x 40 mm	ID 70634

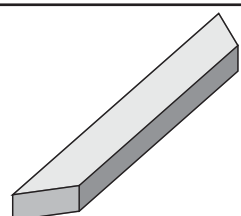

1 x C3	932 x 60 x 40 mm	ID 70414
--------	------------------	----------

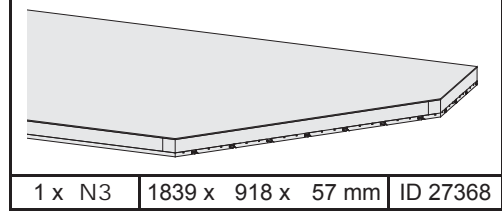

1 x N3 | 1839 x 918 x 57 mm | ID 27368

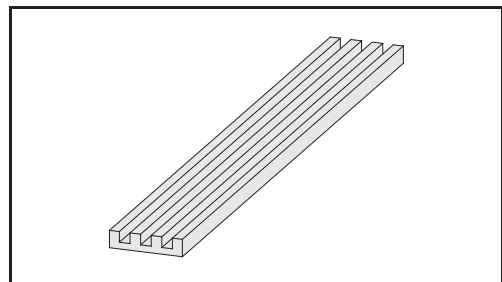

1 x E1 | 1820 x 140 x 26 mm | ID 26480

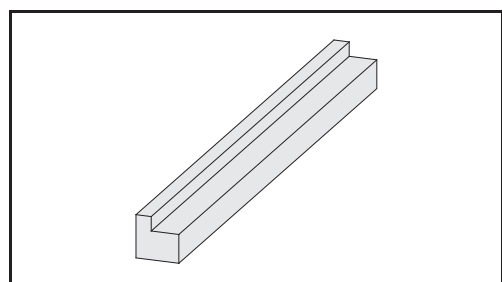

2 x E2 | 555 x 45 x 45 mm | ID 40301
3 x E3 | 1100 x 45 x 45 mm | ID 40302

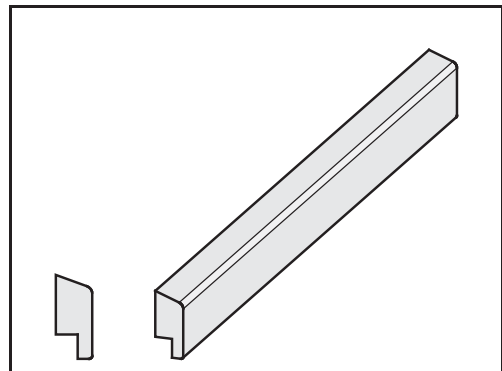

1 x E4 | 960 x 52 x 23 mm | ID 22599

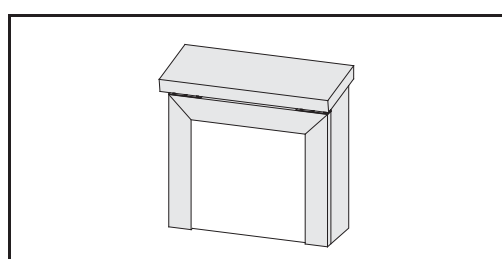

1 x H1 | 340 x 318 x 157 mm | ID 63452

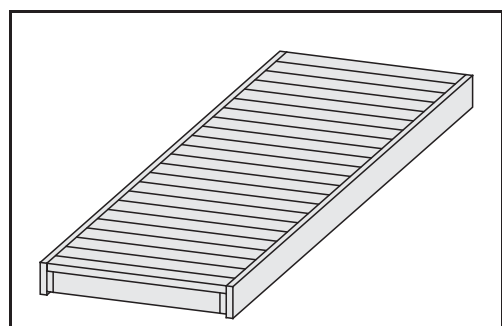

1 x L1 | 1200 x 550 x 95 mm | ID 27341
2 x L2 | 2156 x 550 x 95 mm | ID 52068

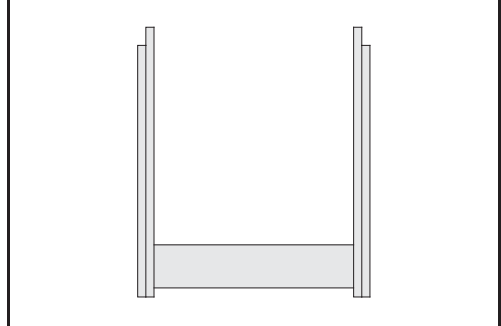

1 x L3 | 860 x 512 x 95 mm | ID 65739

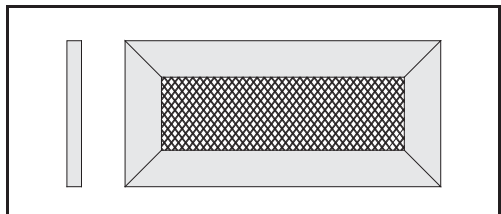

2 x | | ID 86726

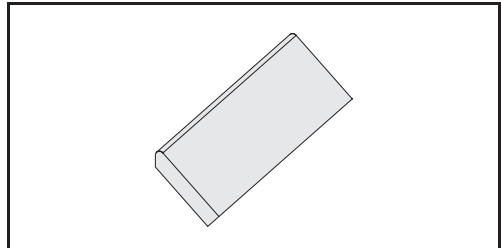

2 x M1 | 400 x 95 x 18 mm | ID 27167

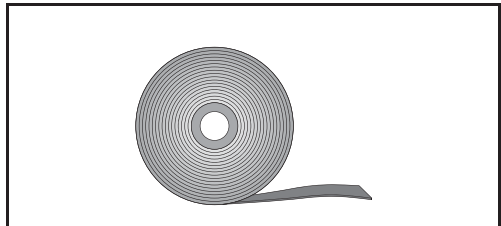

10 m | | ID 14025



1 x | | ID 71504

30 x	4 x 30 mm	ID 3686
175 x	4 x 35 mm	ID 3687
80 x	4 x 40 mm	ID 21925
95 x	4 x 50 mm	ID 3688
105 x	4 x 60 mm	ID 21207
280 x	4 x 70 mm	ID 3689
15 x	4,5 x 80 mm	ID 9204
5 x	6 x 60 mm	ID 14014
20 x	6 x 80 mm	ID 47558
20 x	6 x 100 mm	ID 11749

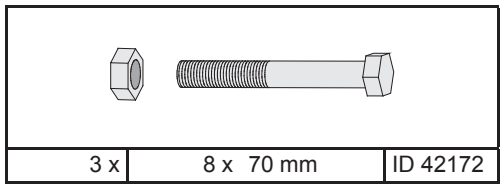

3 x | 8 x 70 mm | ID 42172

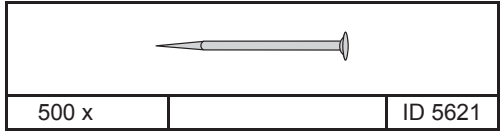

500 x | | ID 5621

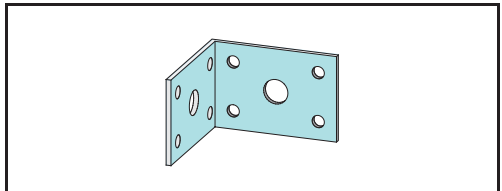

8x | | ID 21292

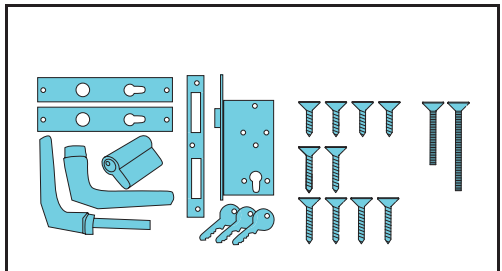

1 x | | ID 15979

5 x	3 x 16mm	ID 46376

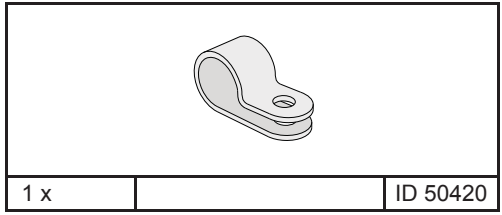



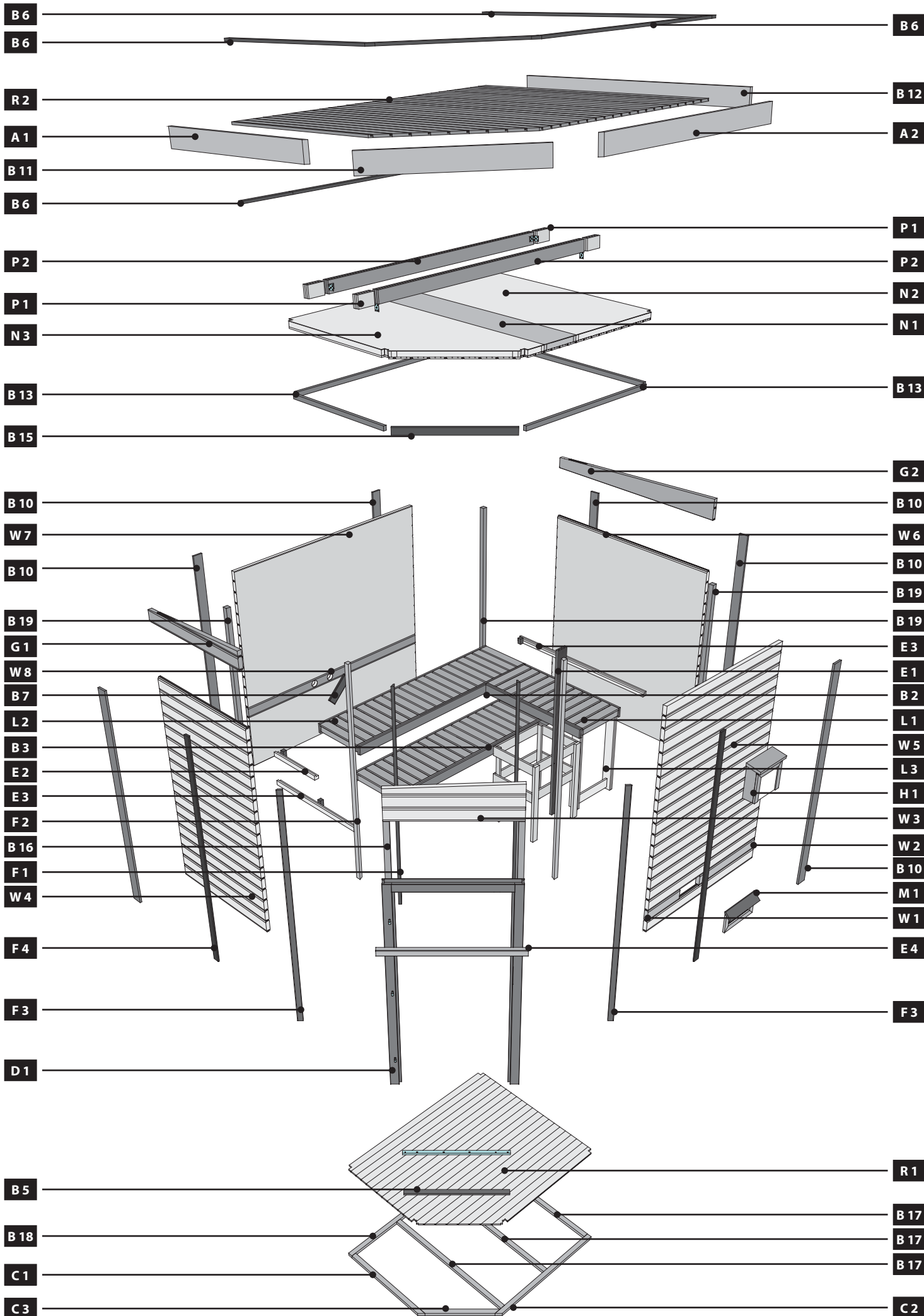

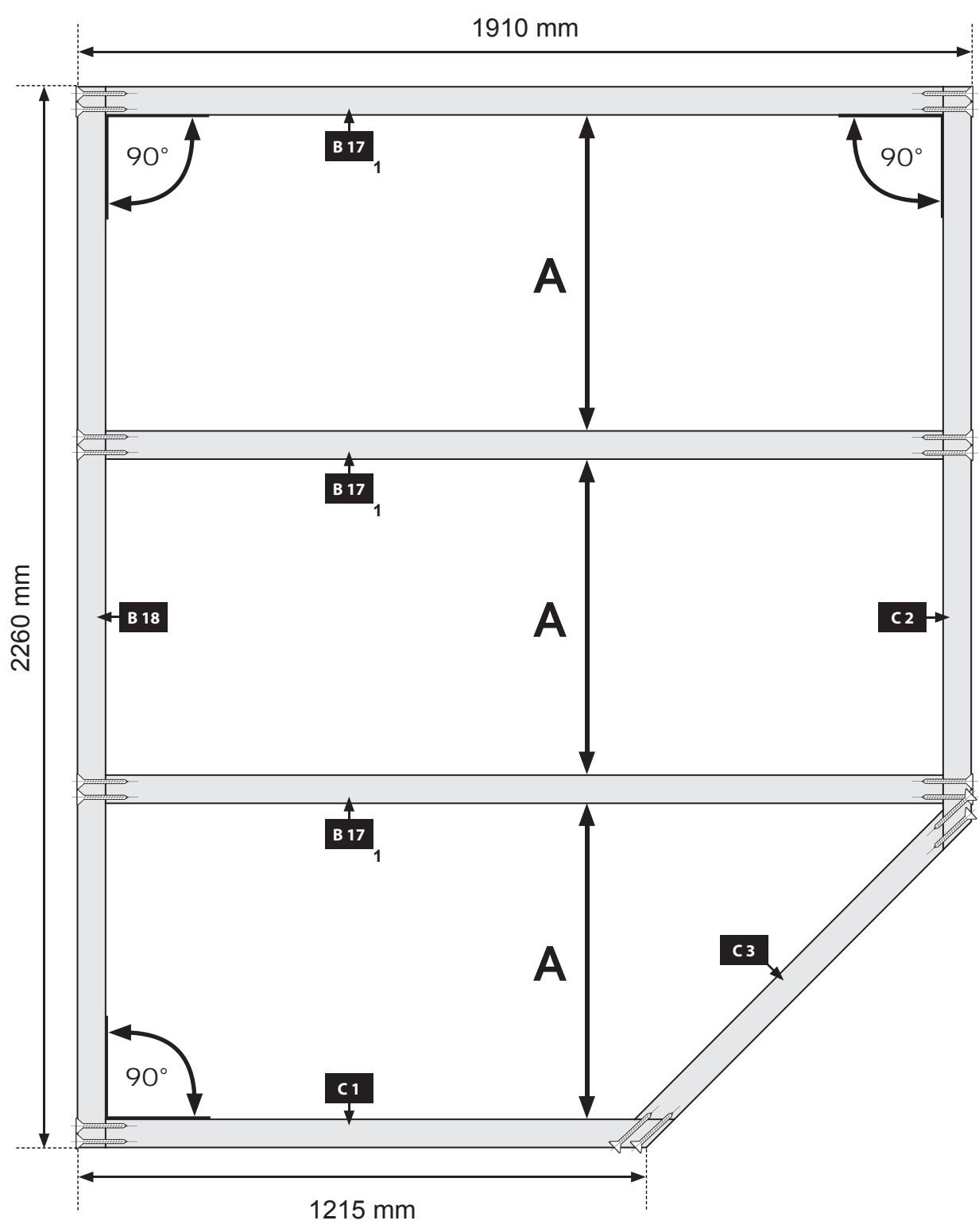
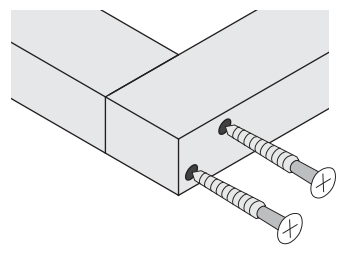
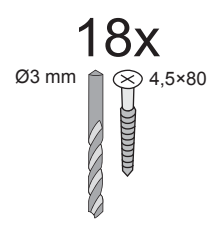
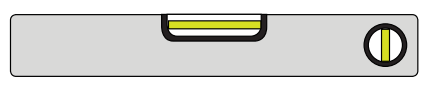

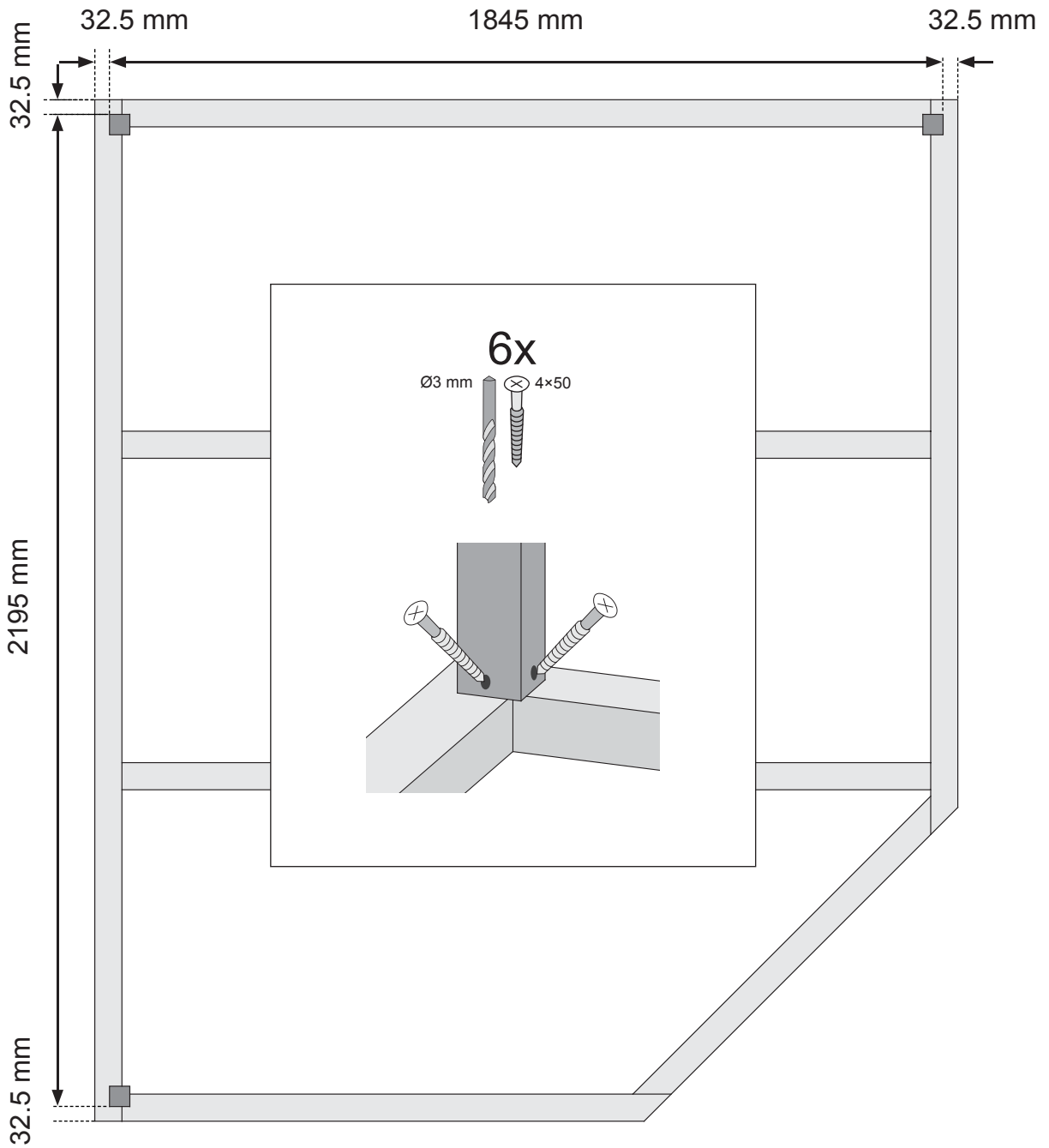
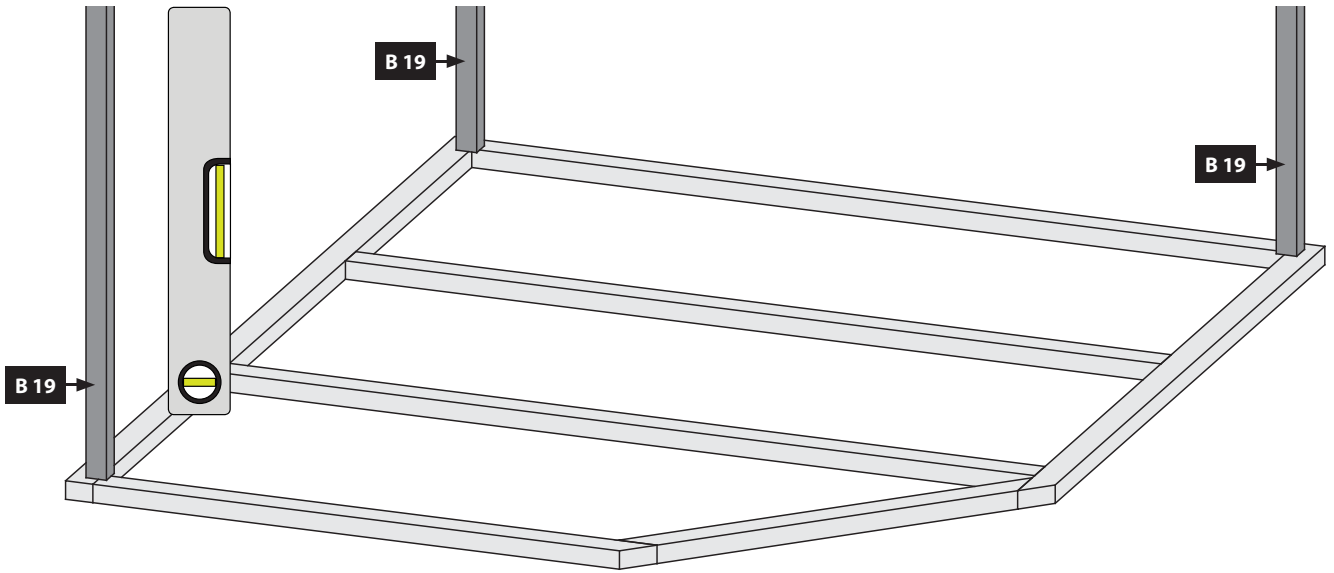
1 x | | ID 50420









 Leim! Achten Sie auf die gleiche Höhe
 Glue! Look for the same height
 Colle! Faites attention à la même hauteur



 Lijm! Besteed aandacht aan de dezelfde hoogte
 Lim! Vær opmærksom på samme højde
 Pegamento! Prestar atención a la misma altura

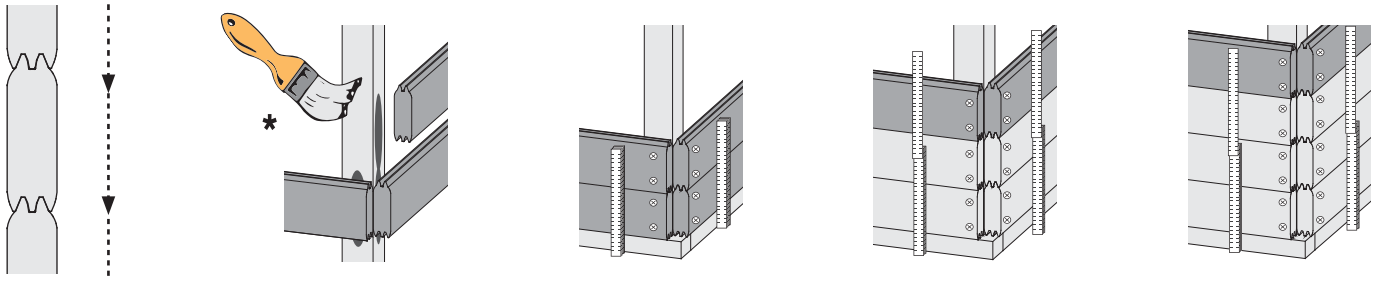

 Colla! Prestare attenzione alla stessa altezza
 Klíh! Dávejte pozor na stejnou výšku

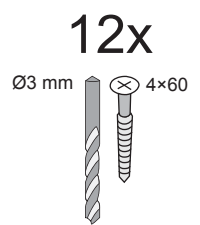
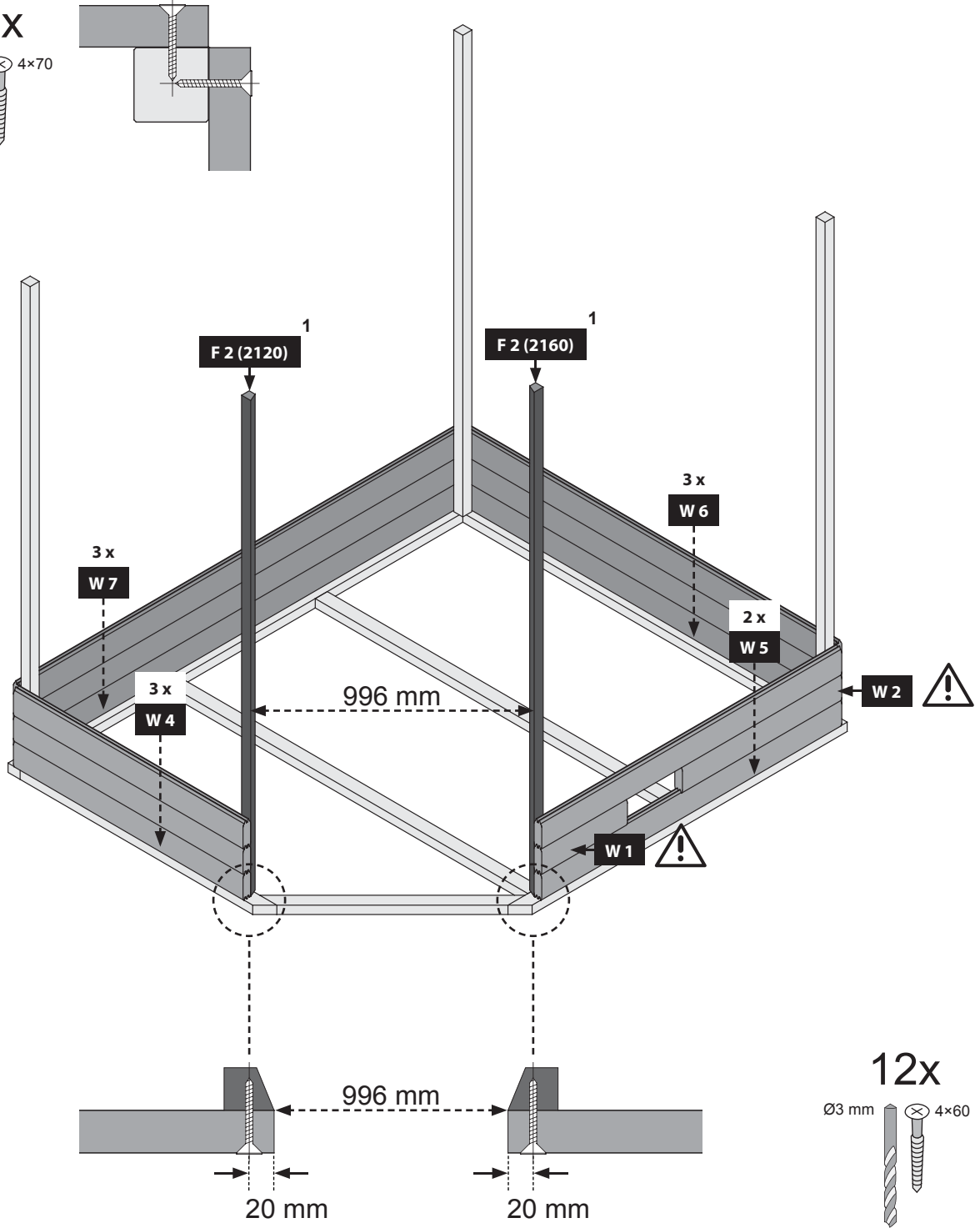
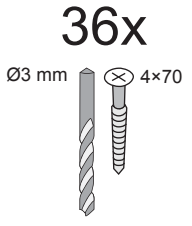



03



 Leim! Achten Sie auf die gleiche Höhe
 Glue! Look for the same height
 Colle! Faites attention à la même hauteur

 Lijm! Besteed aandacht aan de dezelfde hoogte
 Lim! Vær opmærksom på samme højde
 Pegamento! Prestar atención a la misma altura

 Colla! Prestare attenzione alla stessa altezza
 Klíč! Dávejte pozor na stejnou výšku

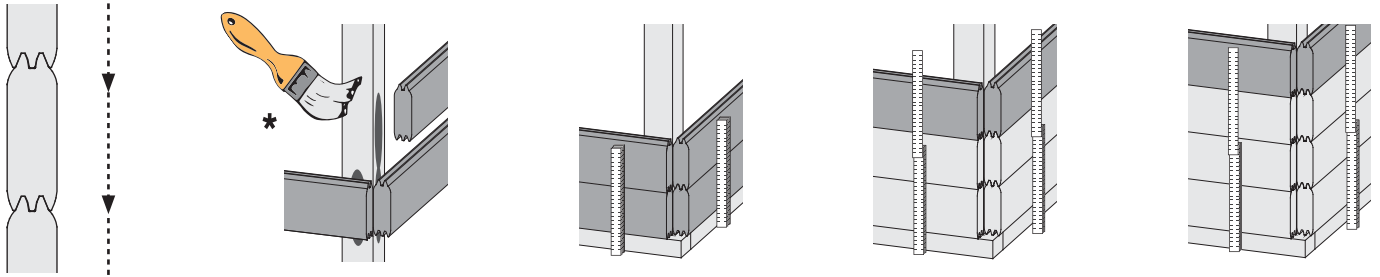

04

60x

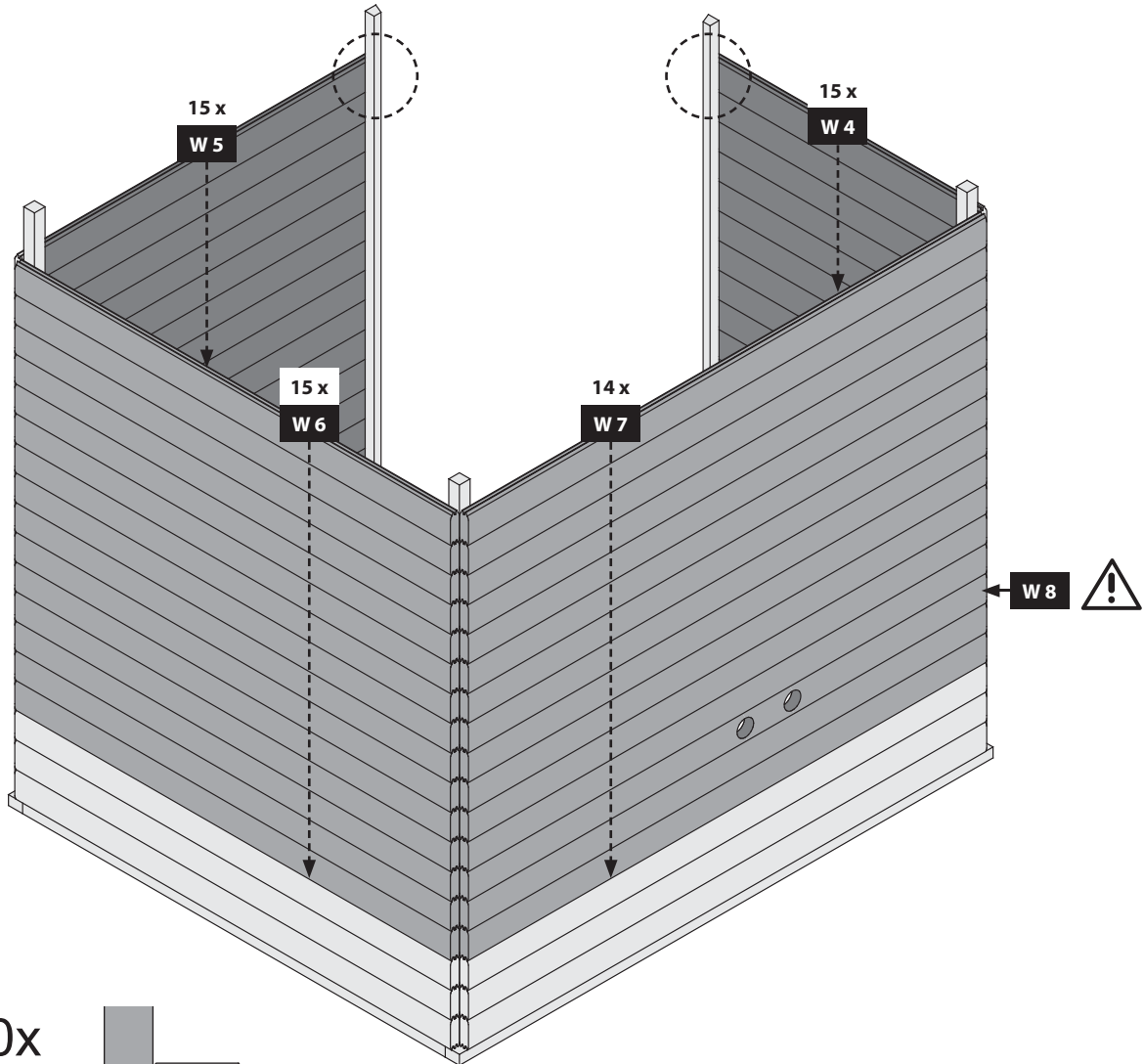
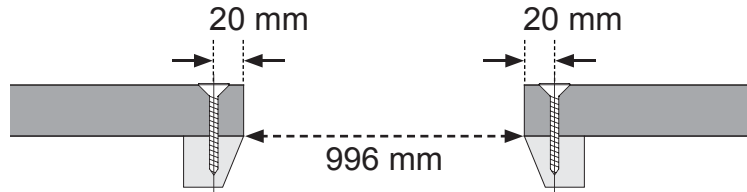
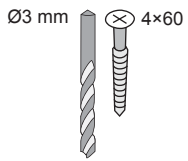

180x

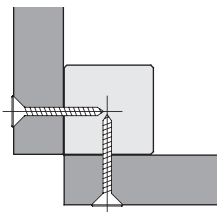
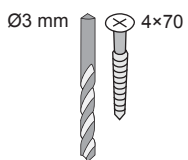

-  Bündig!
-  Flush!
-  Affleurement!
-  I flugt!
-  Gelijk!
-  Aras!
-  Combacia!
-  Stejný !

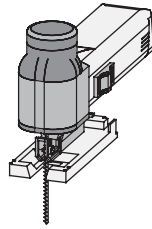

8x

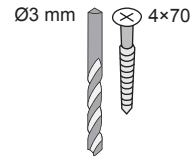

3x

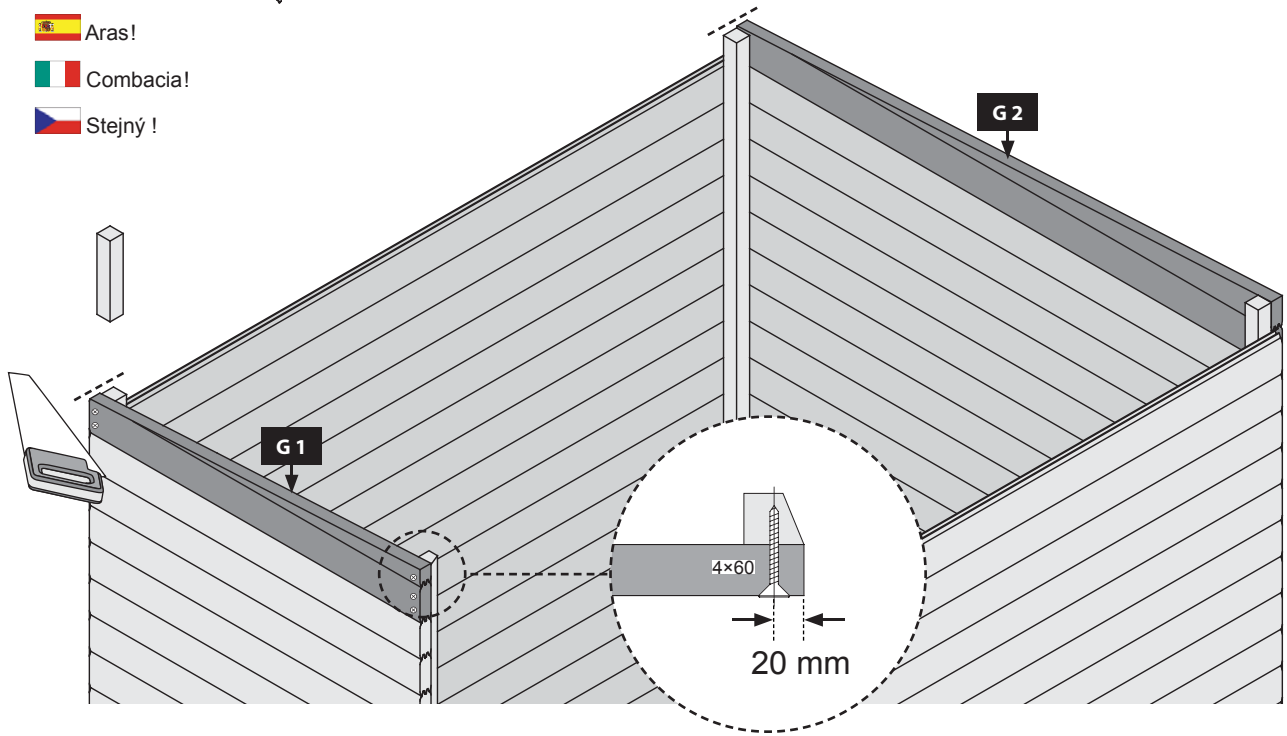
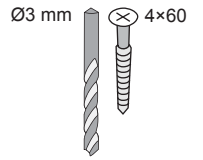

-  Bündig!
-  Flush!
-  Affleurement!
-  I flugt!
-  Gelijk!
-  Aras!
-  Combacia!
-  Stejný !

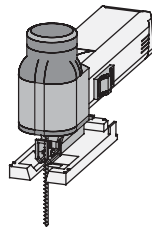

8x

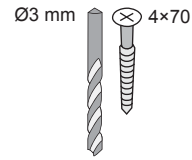

4x

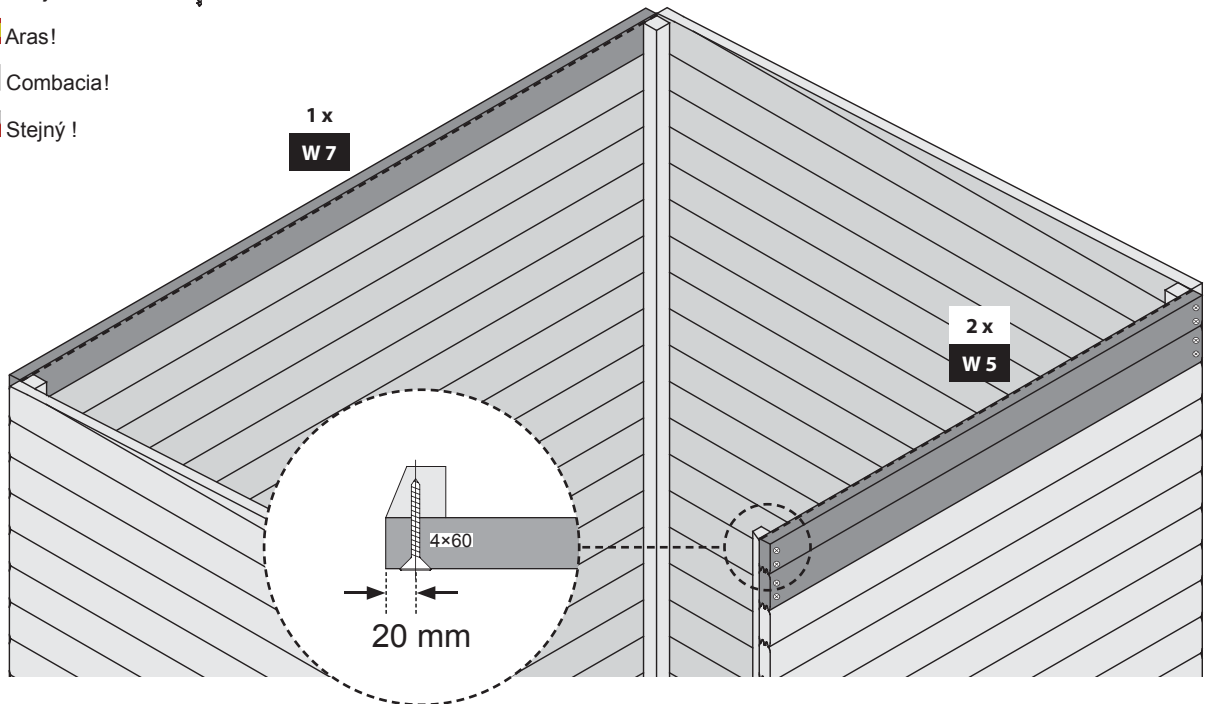
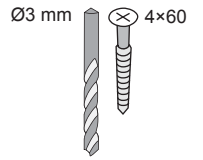

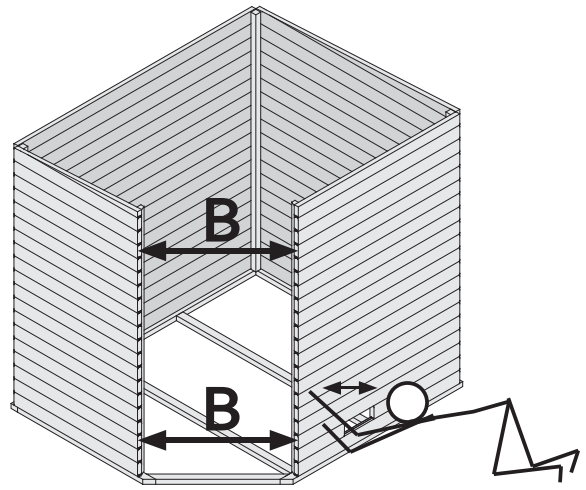
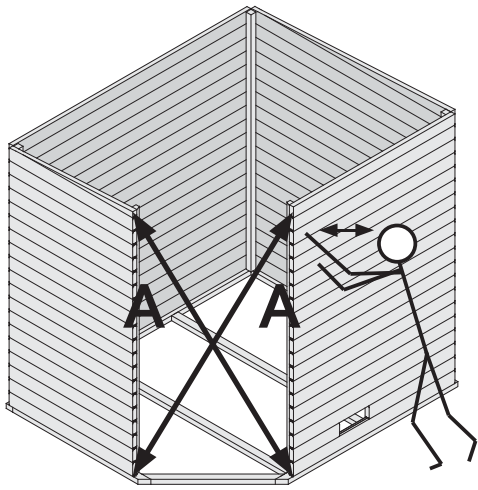

07

 Leim

 Glue

 Colle

 Lim

 Lijm

 Pegamento

 Colla

 Klijh

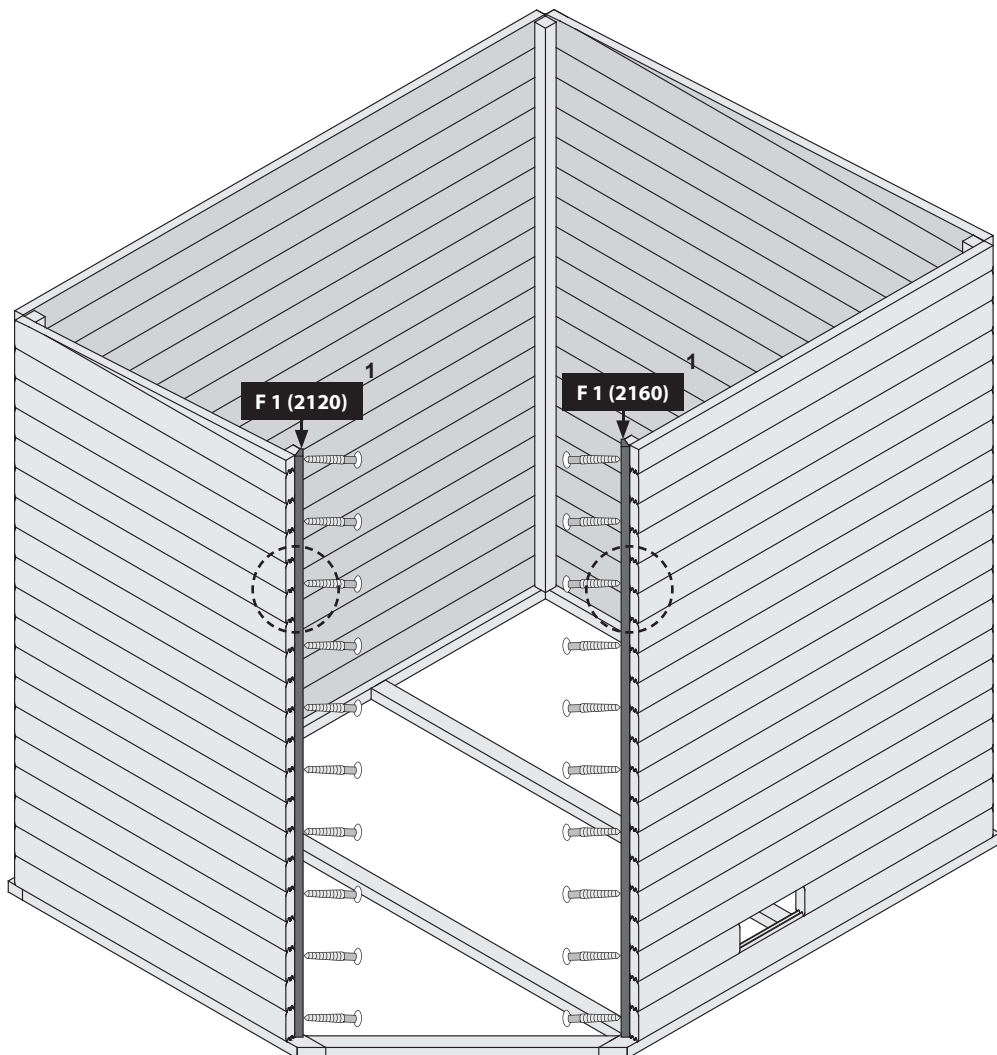
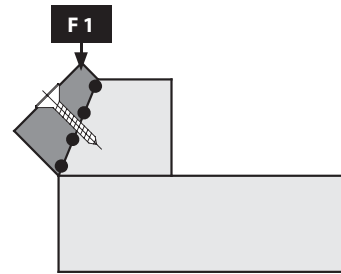
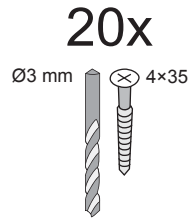
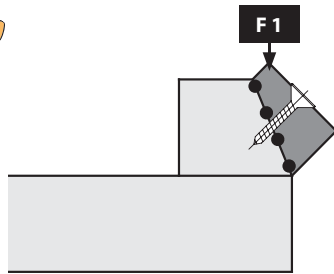

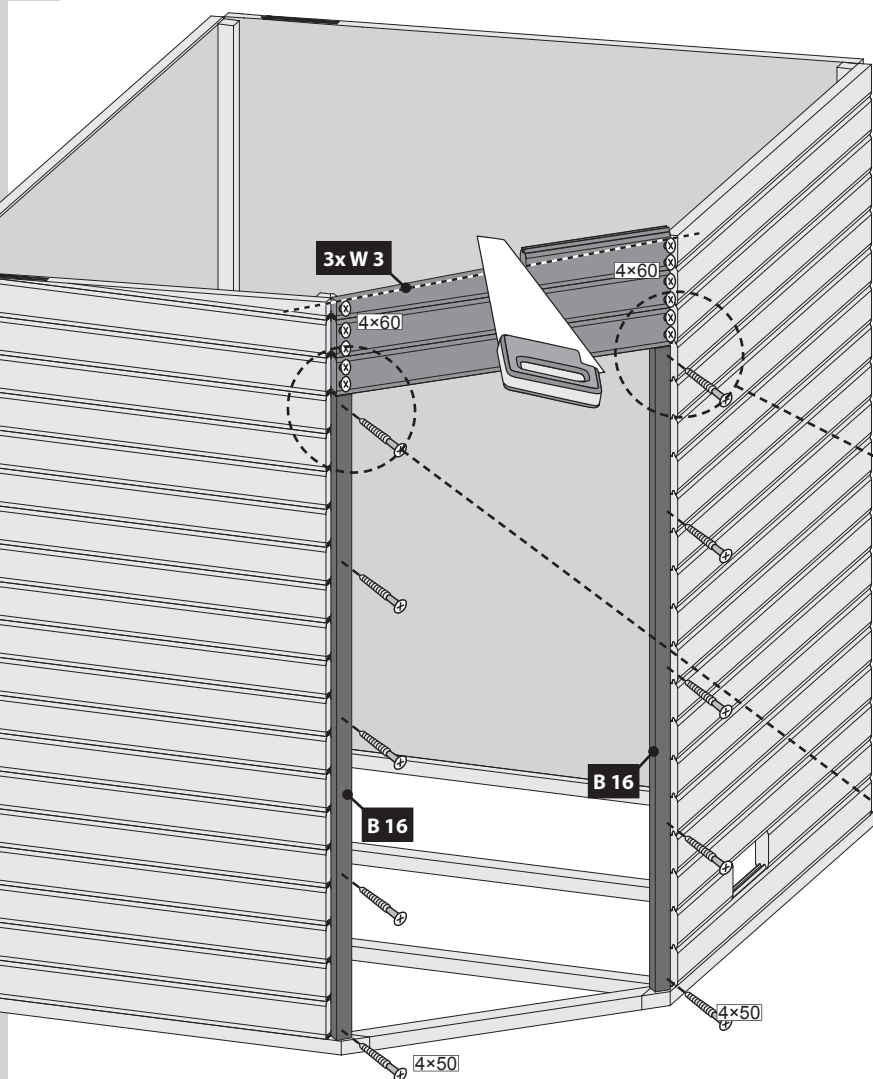

- Ø3 mm 4x60
- 11x
- Ø3 mm 4x50
- 10x

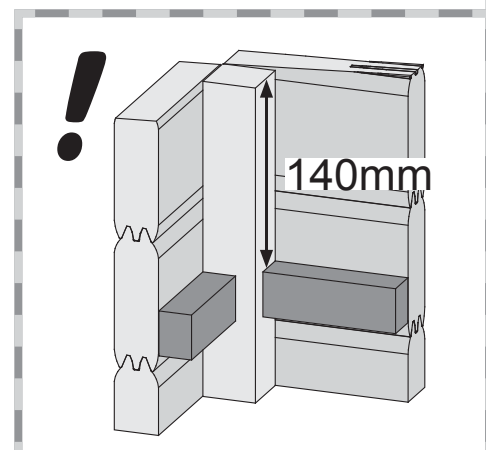
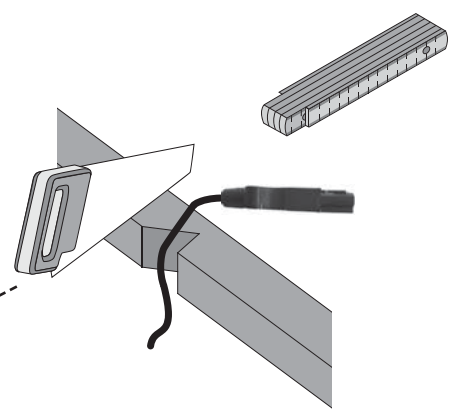
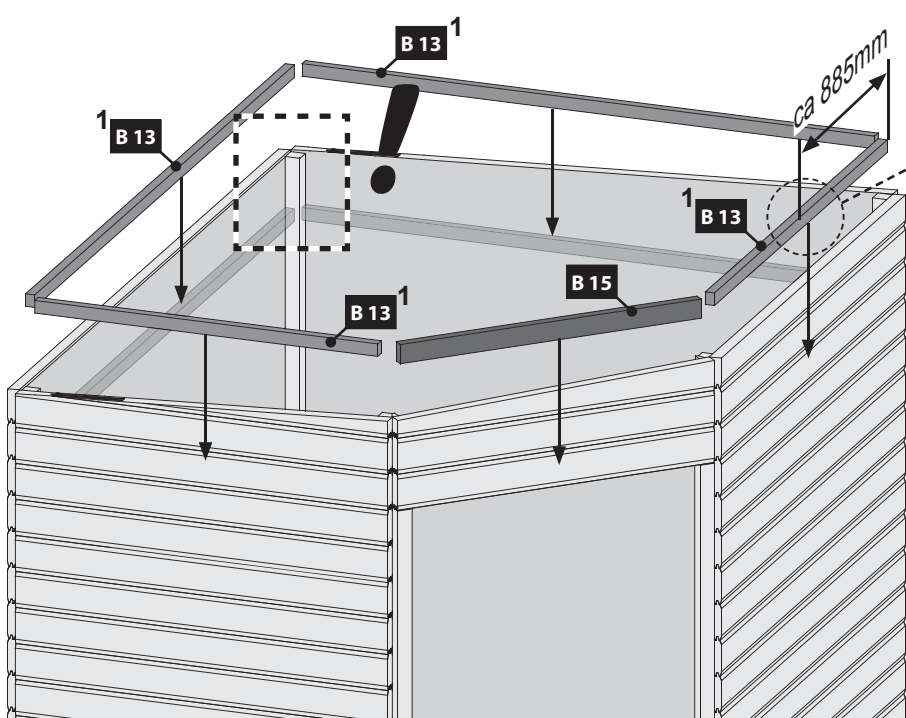
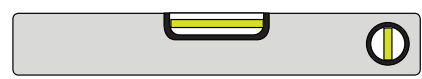
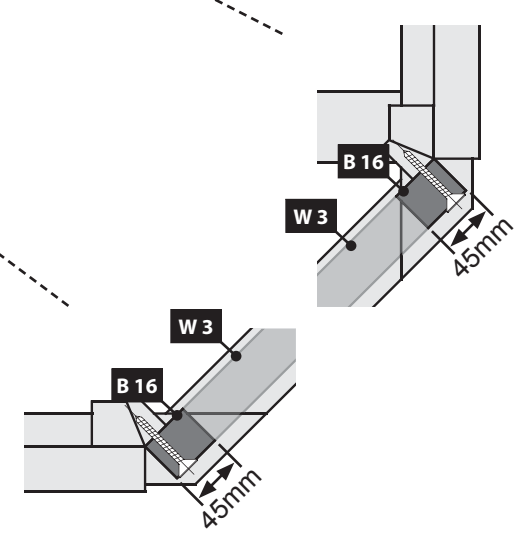

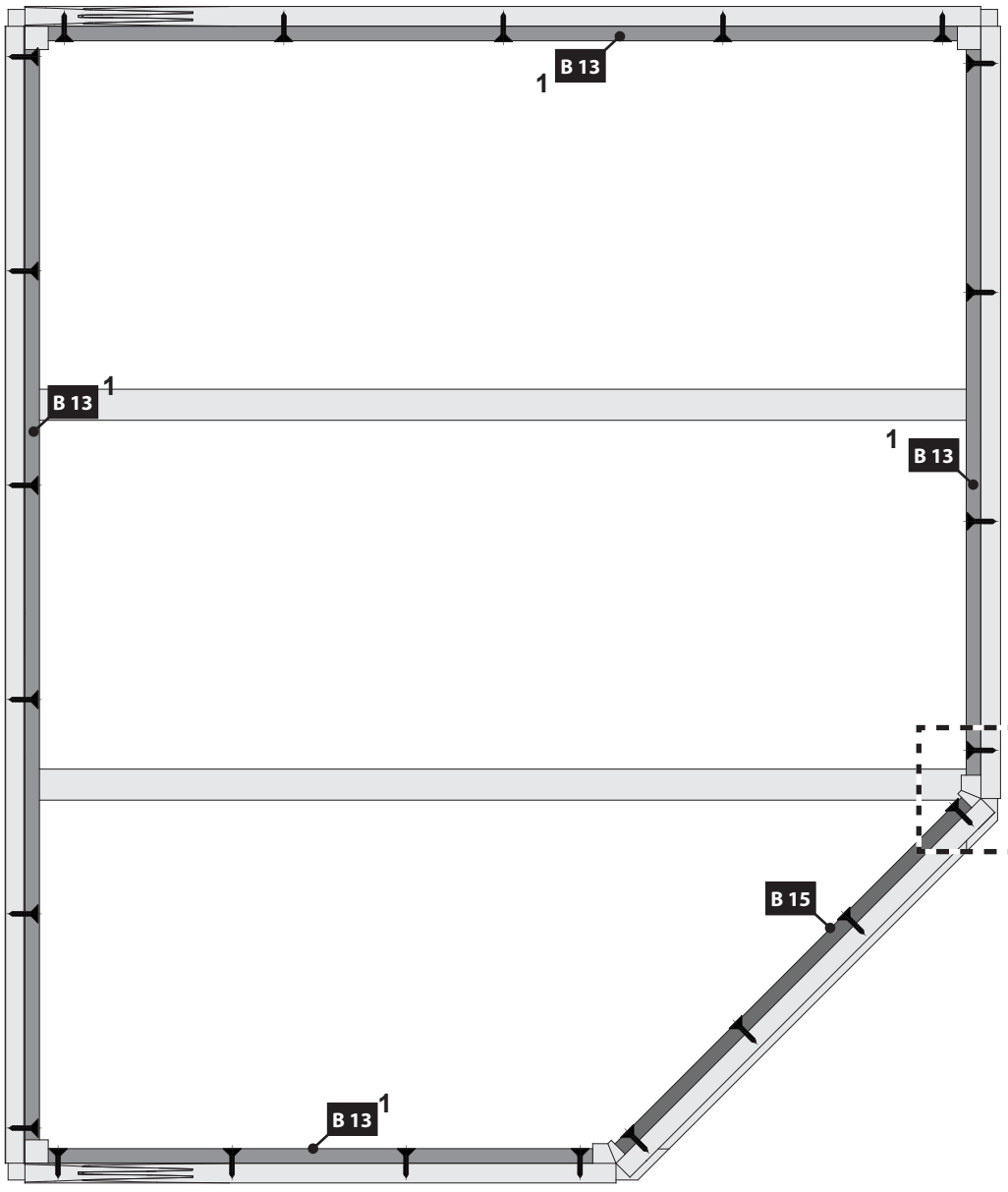

Ø3 mm 4x40

23x

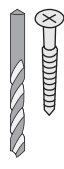

-  Bündig!
-  Flush!
-  Affleurement!
-  Gelijk!
-  I flugt!
-  Aras!
-  Combacia!
-  Stejný !

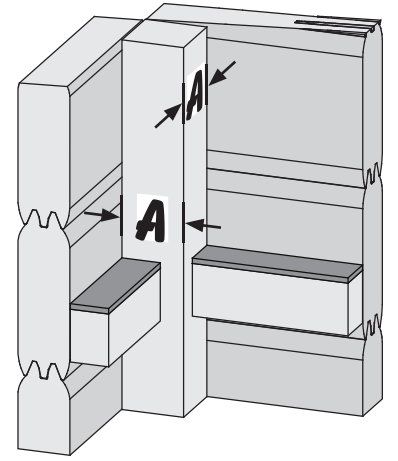
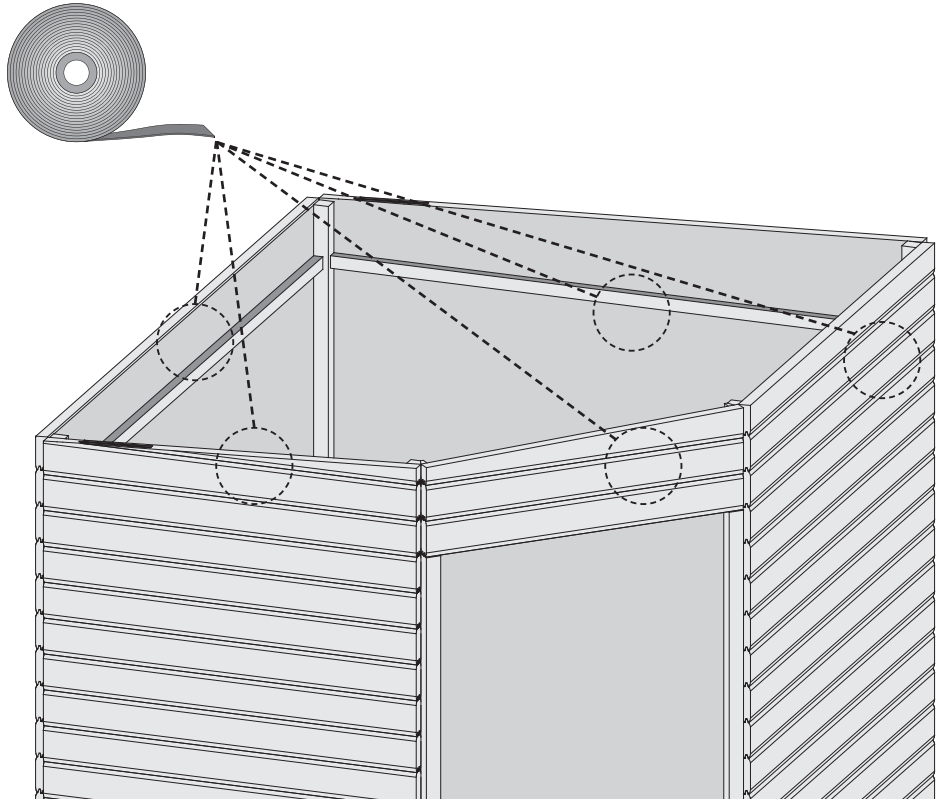
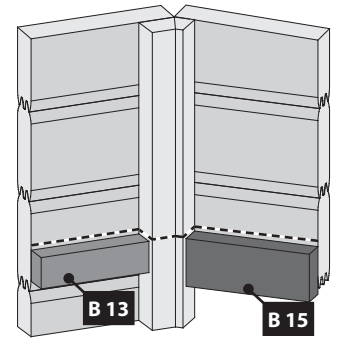

12

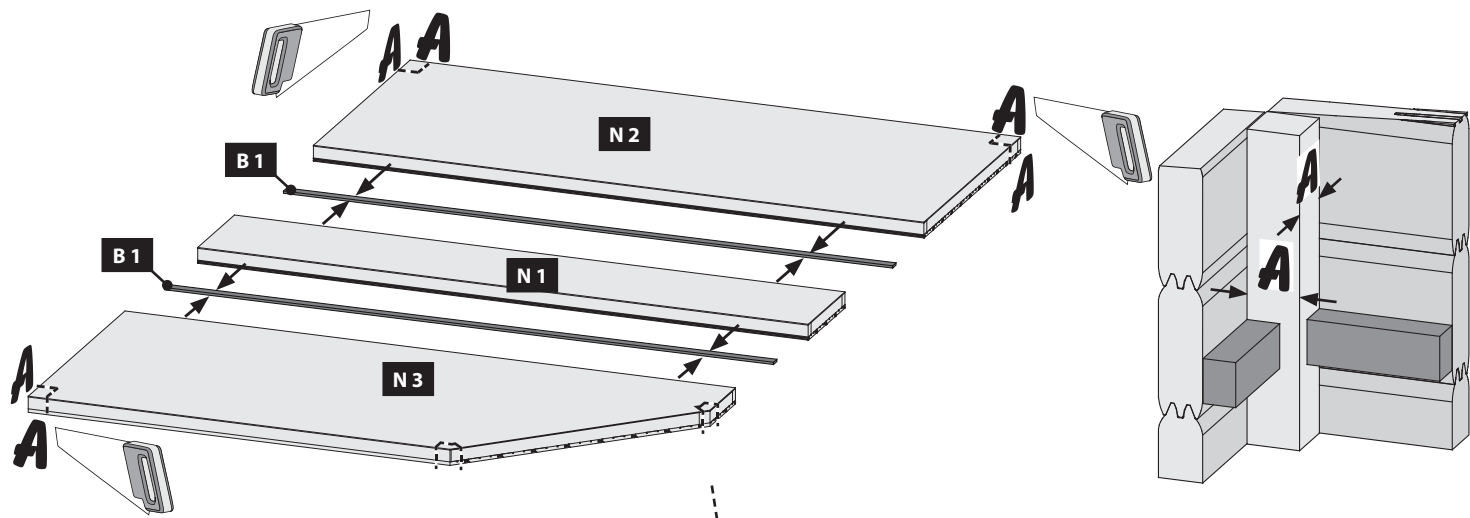

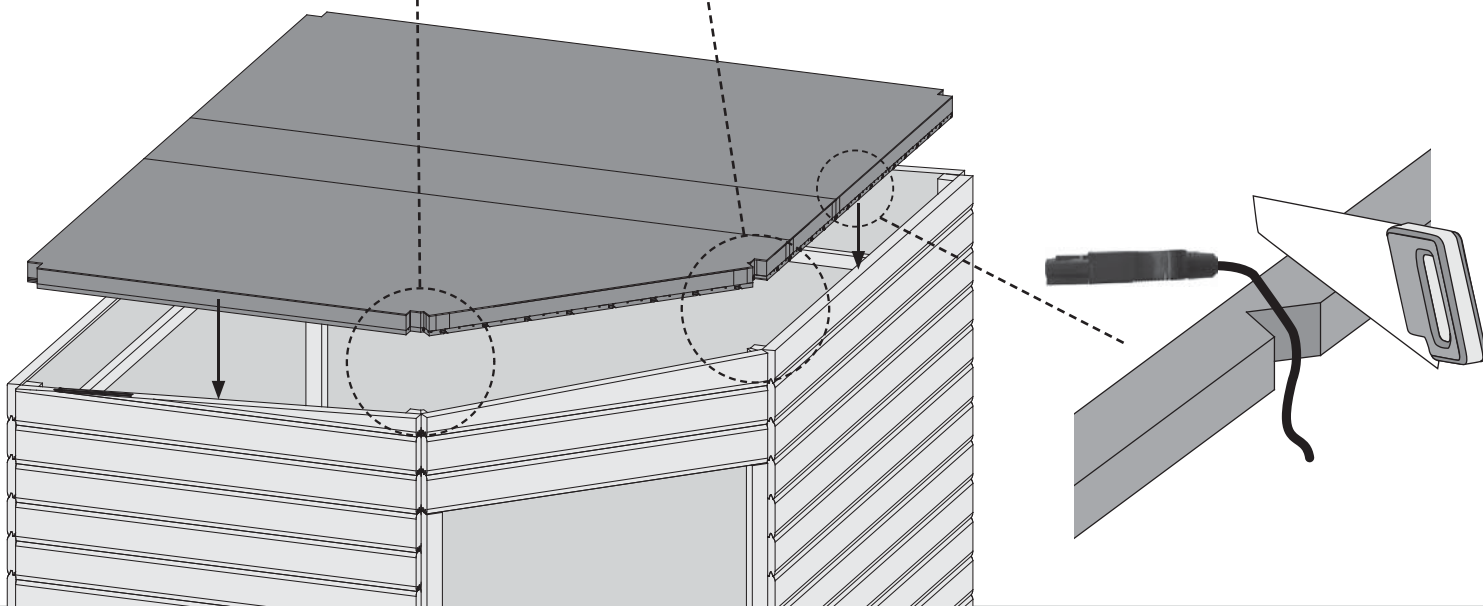

13



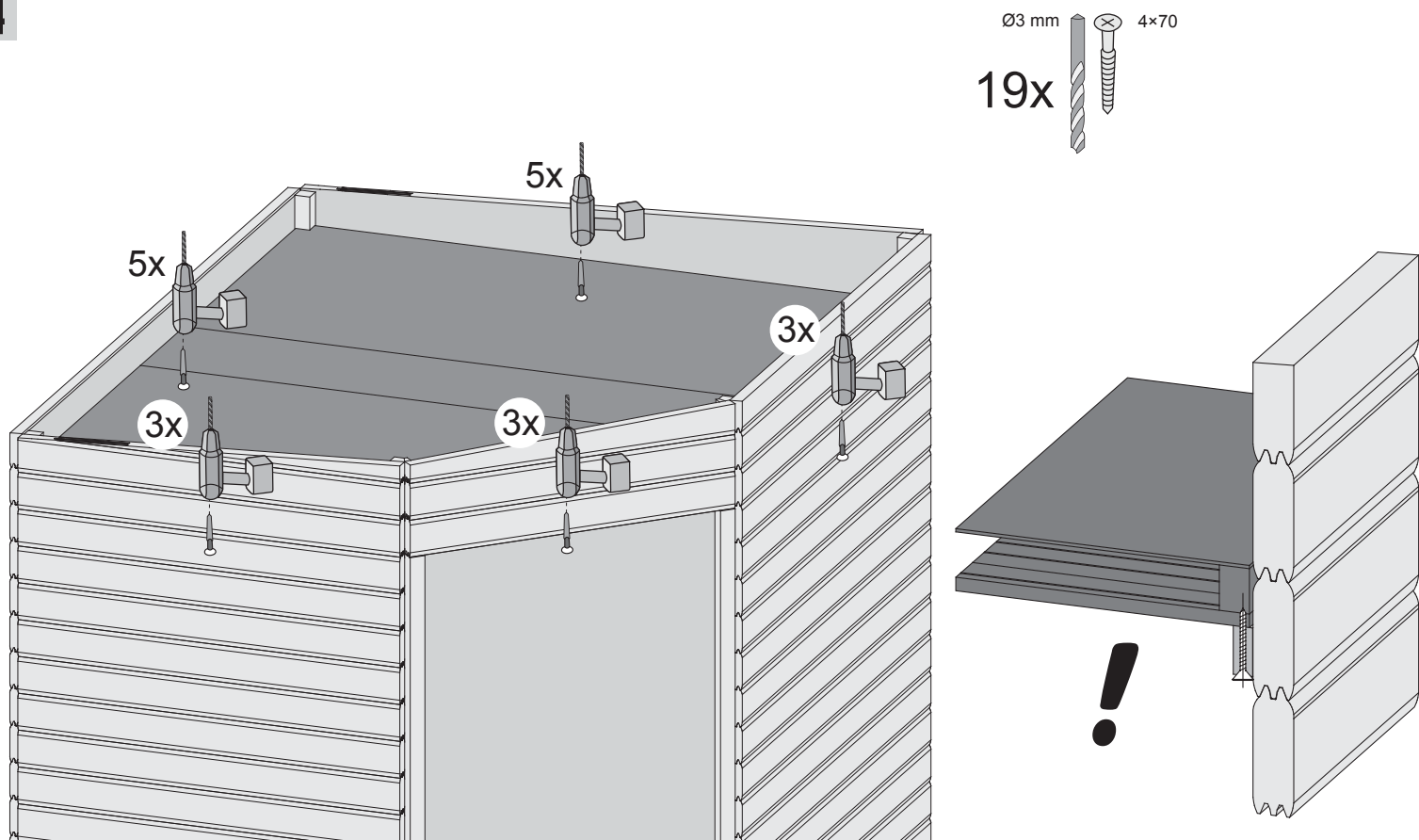



14





 Breite Seite nach oben
 Width side up
 Largeur vers le haut

 Breedte side up
 Ancho de banda de hasta
 Larghezza verso l'alto

 Šířka stranou nahoru
 Bred side op

15

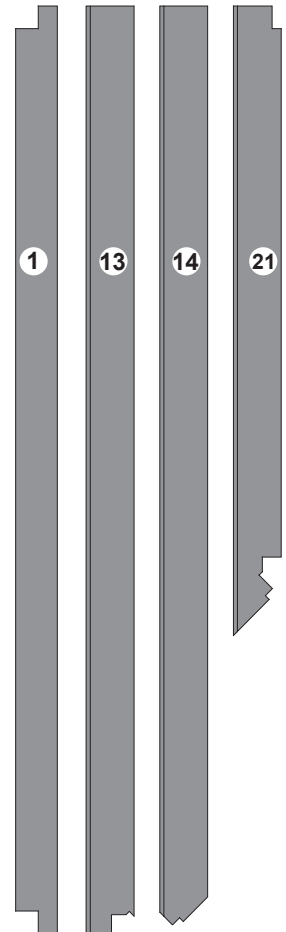
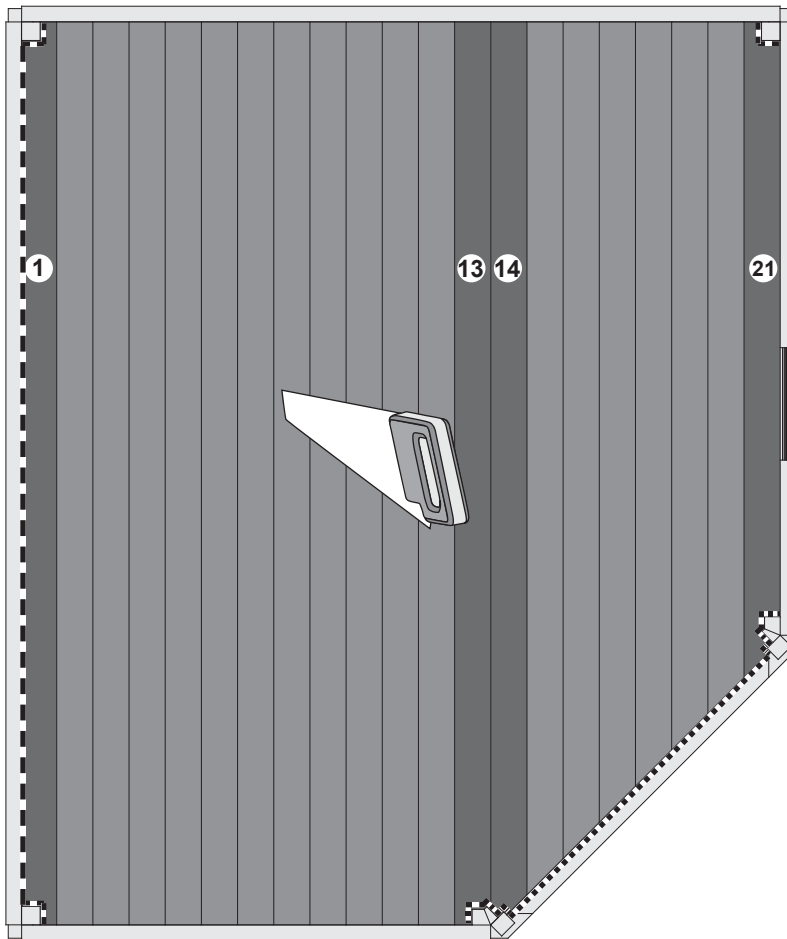
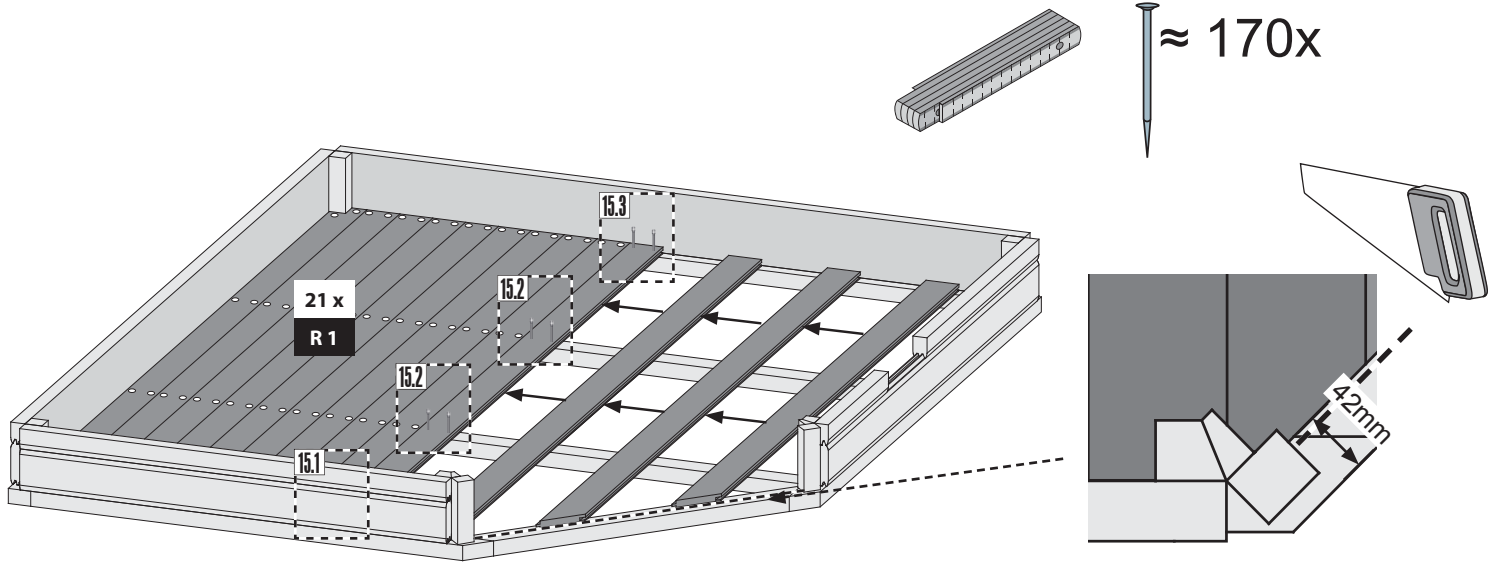

15.1

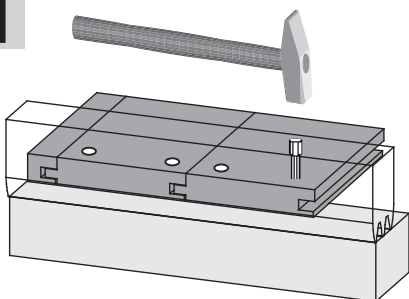

15.2

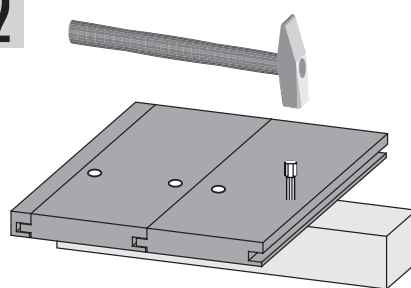



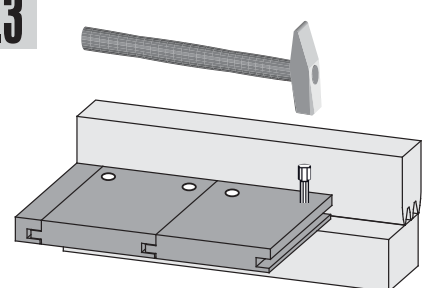

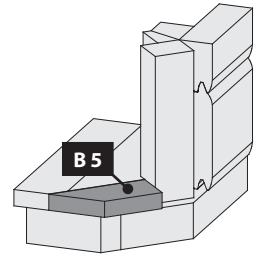
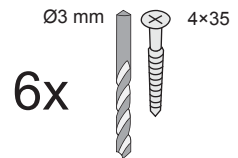
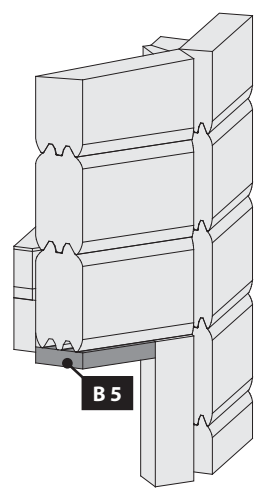
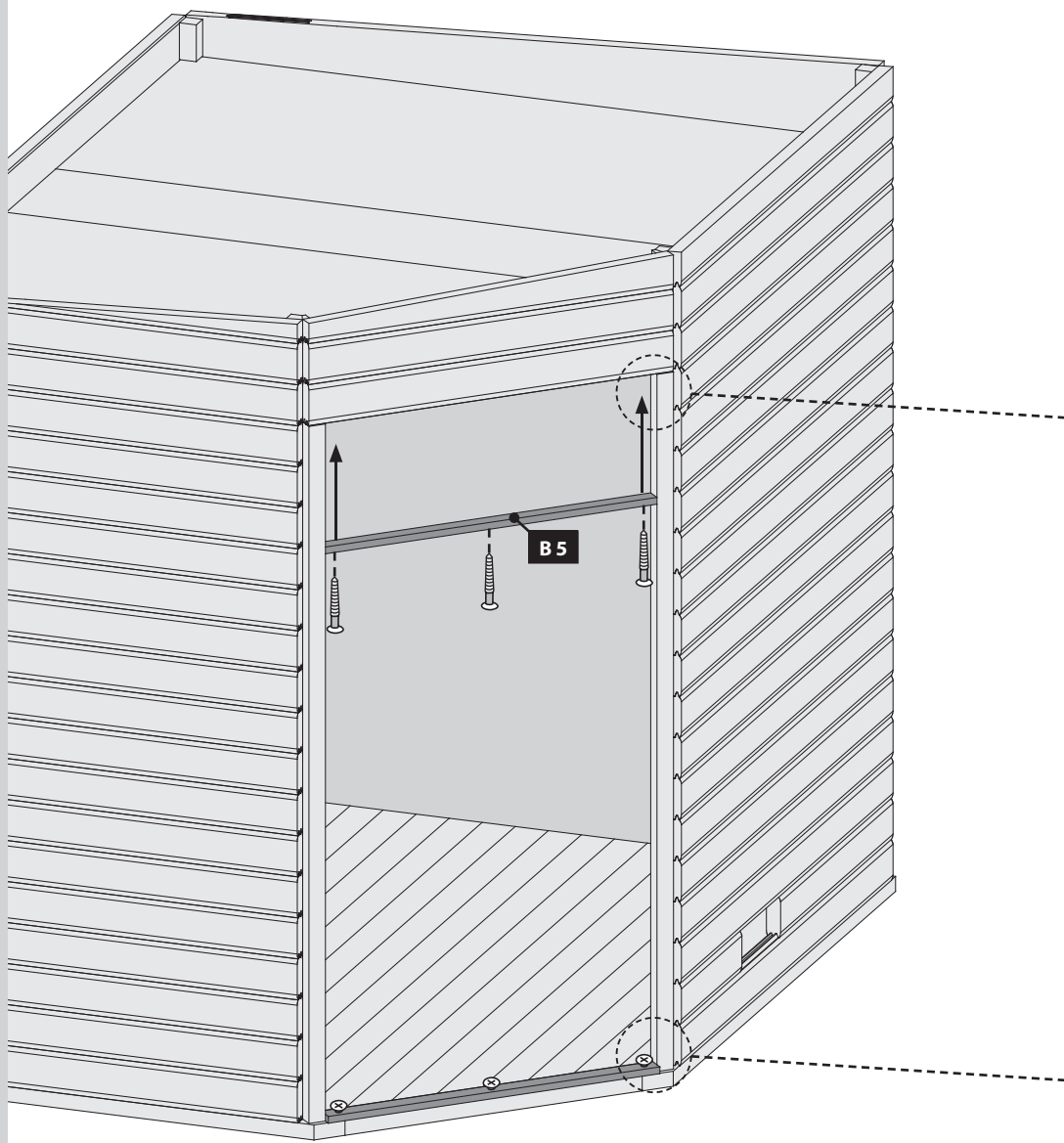
15.3





 Einbau Tür
 Installation door
 Porte d'installation

 Installatie deur
 Installationsdør
 Puerta de instalación

 Porta di installazione
 Montážní dveře

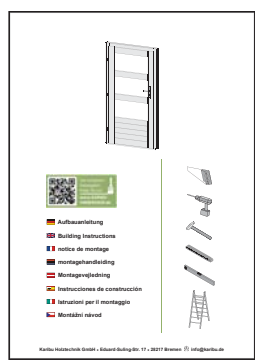

 Siehe Türpaket
 Opmerking Door Package
 Note Door Package
 Remarque Package porte
 Nota Paquete Puerta
 Nota Door Package
 Poznámka Door balíček

Ø3 mm 4x40 Ø3 mm 4x50
 50x 3x 5x

-  Bündig!
-  Flush!
-  Affleurement!
-  Gelijk!
-  I flugt!
-  Aras!
-  Combacia!
-  Stejný!

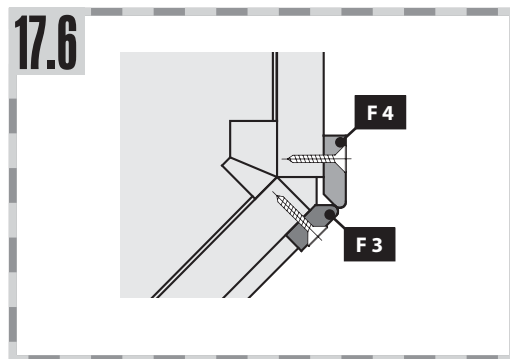
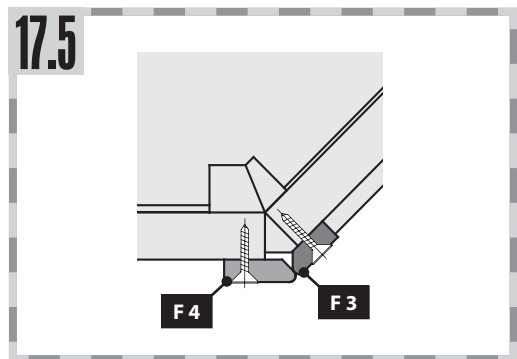
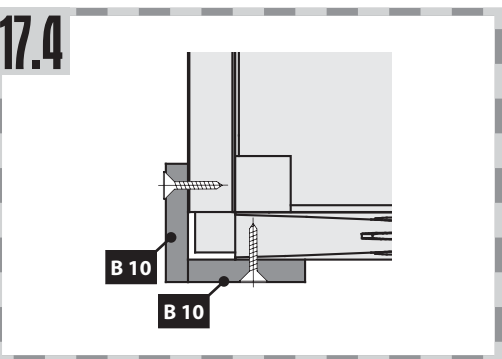
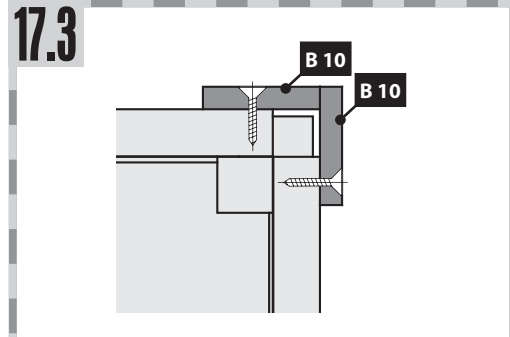
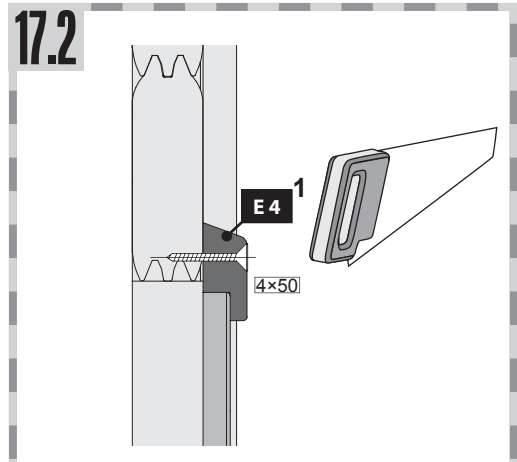
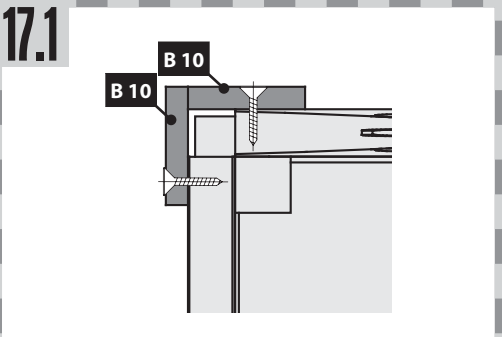
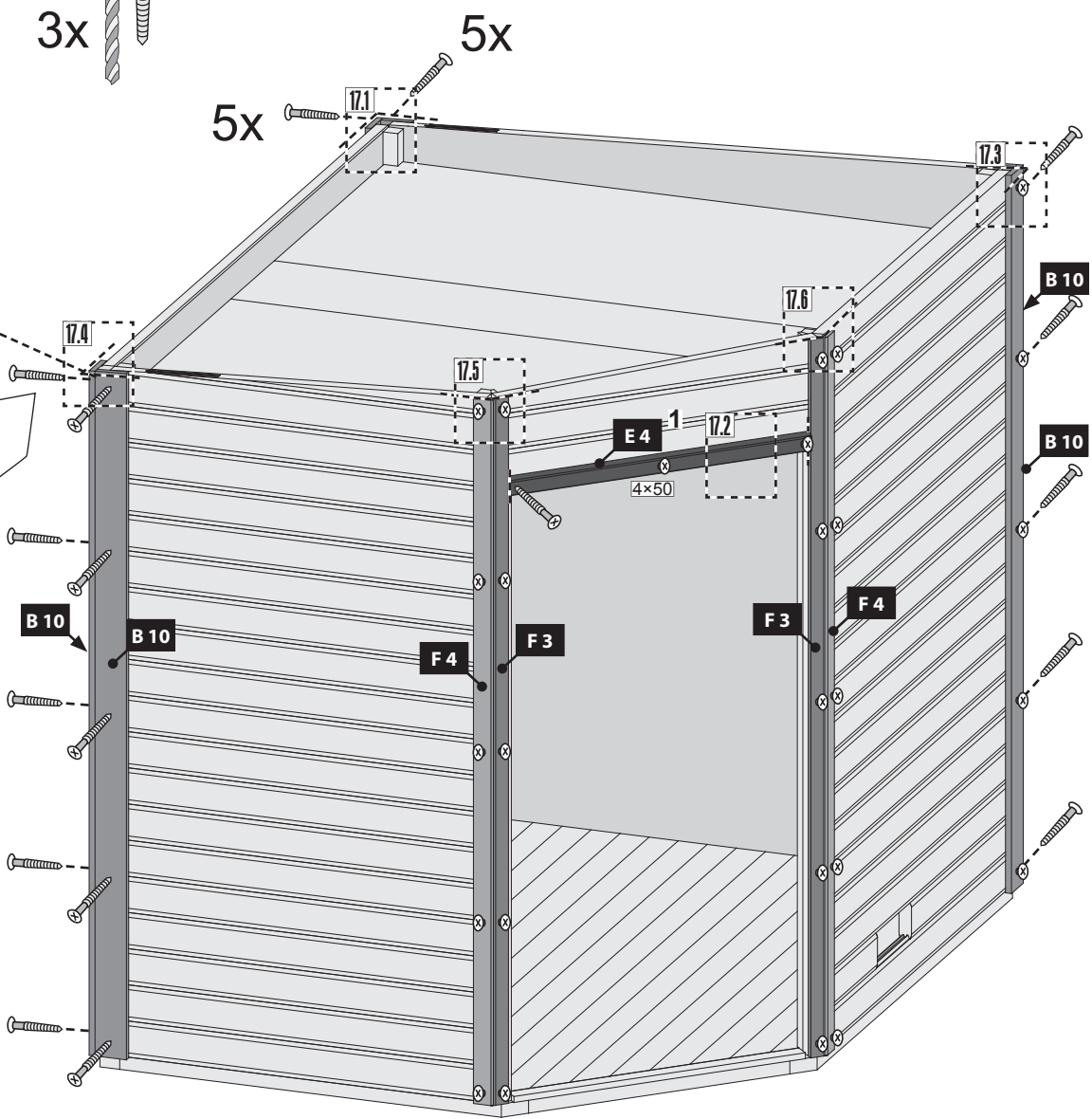

Ø3 mm 4x50
14x

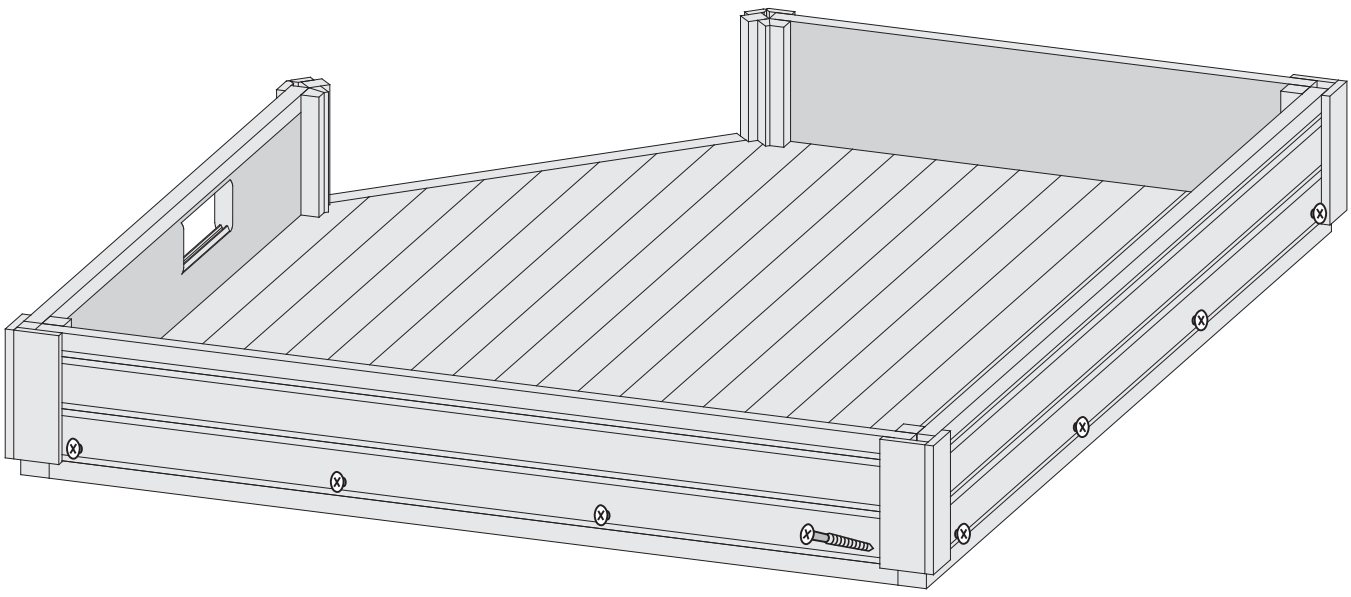
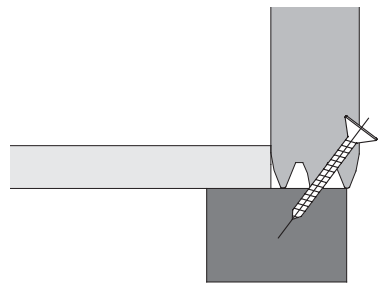
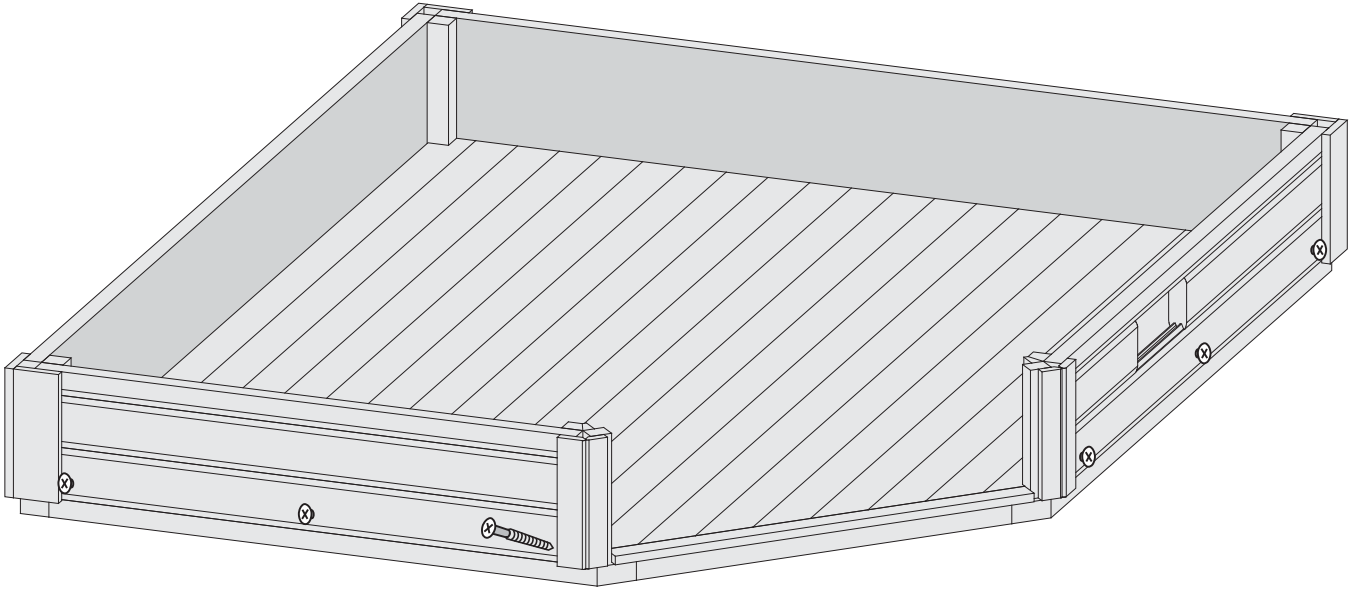
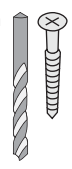

Ø5 mm
16x
6x100

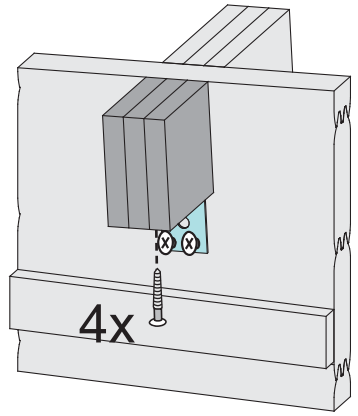
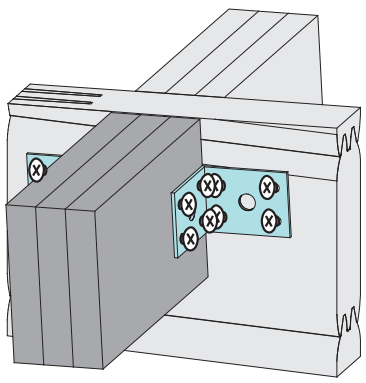
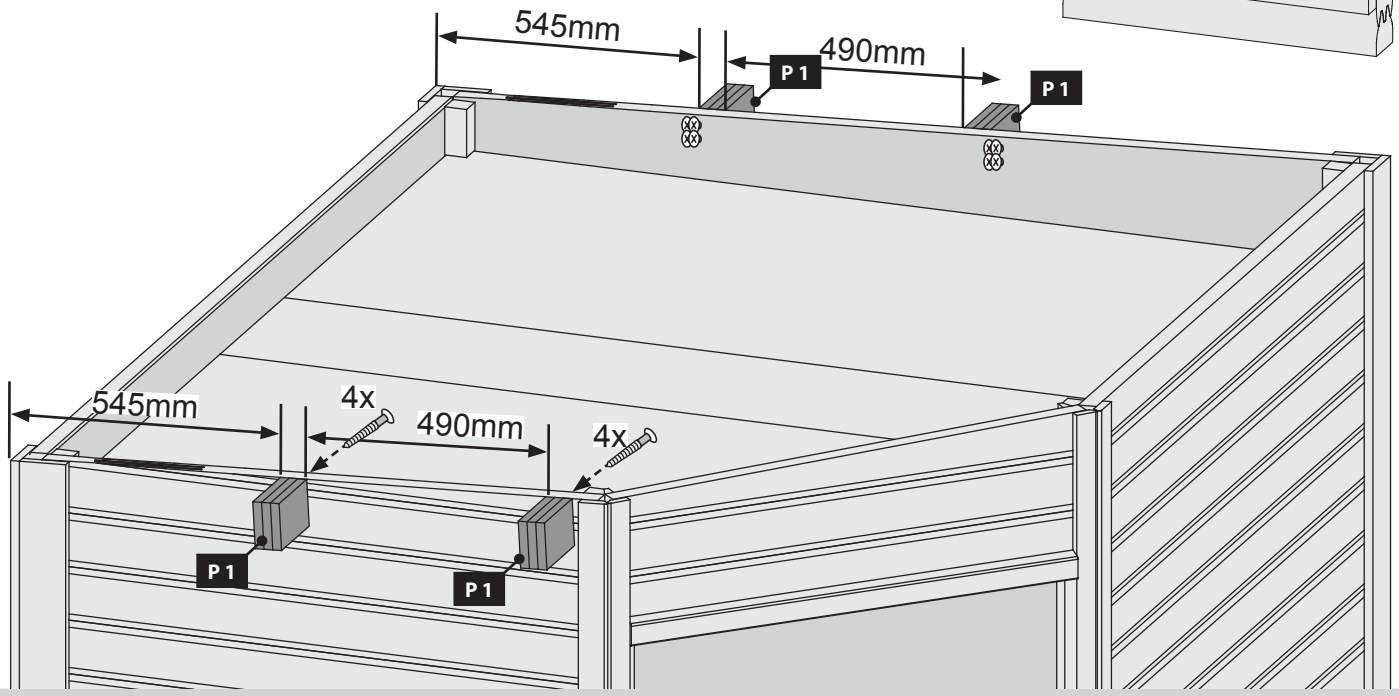
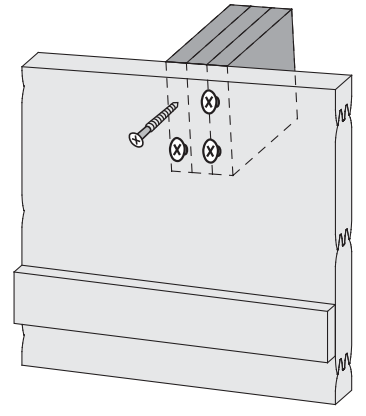

6x

Ø3 mm
48x
4x35

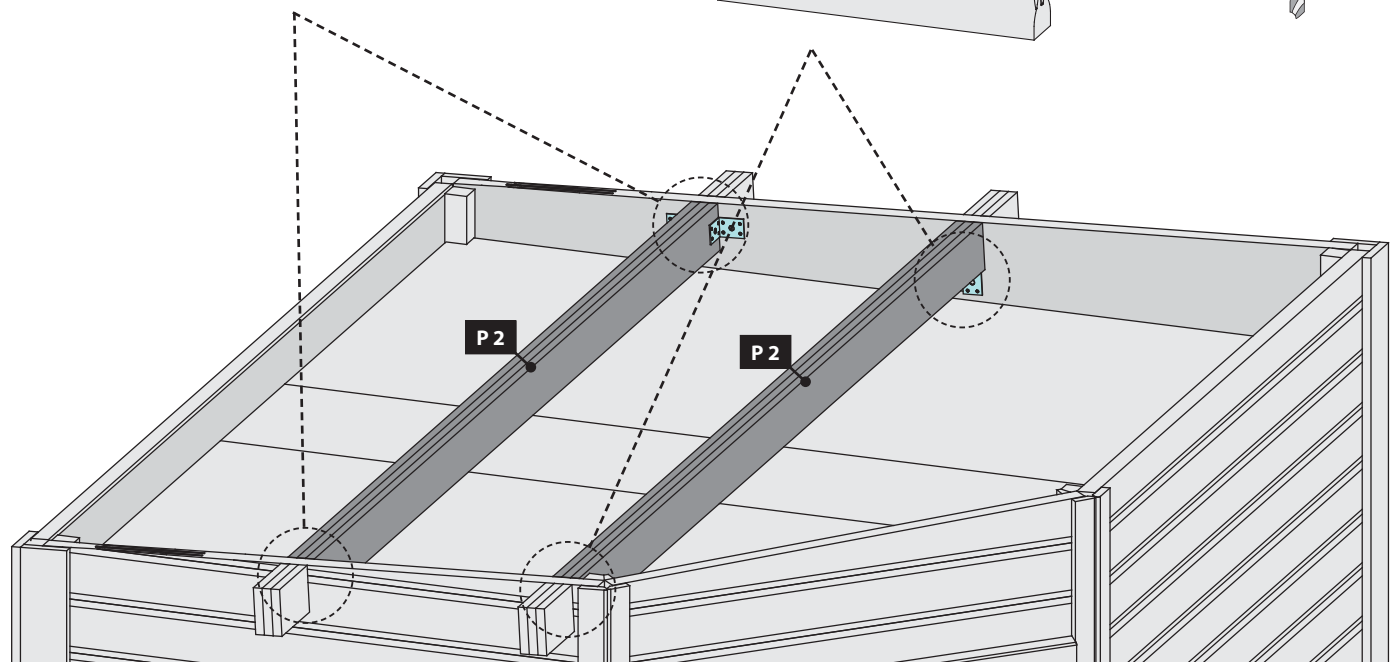

21 2x

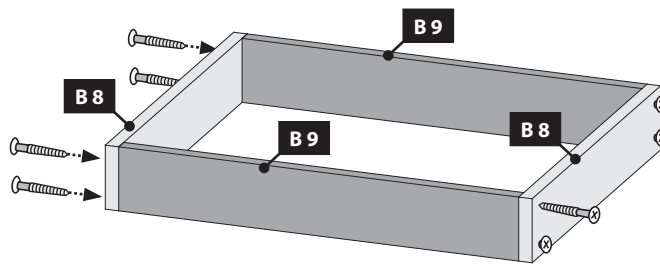





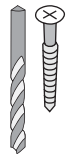



Ø3 mm

16x



4x35

22 a

-  Nur bei 4,5 / 9 kW-Ofen
-  Seulement 4,5 / 9 kW chauffe
-  Only 4,5 / 9 kW heater
-  Slechts 4,5 / 9 kW heater
-  Sólo calentador de 4,5 / 9 kW
-  Solo riscaldamento 4,5 / 9 kW
-  Pouze topné těleso 4,5 / 9 kW
-  Kun ved 4,5 / 9 kW ovn

Ø3 mm

16x

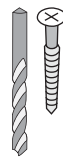

4x35

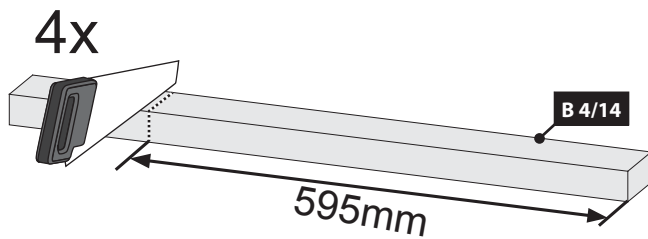

4x

B 4/14

595mm

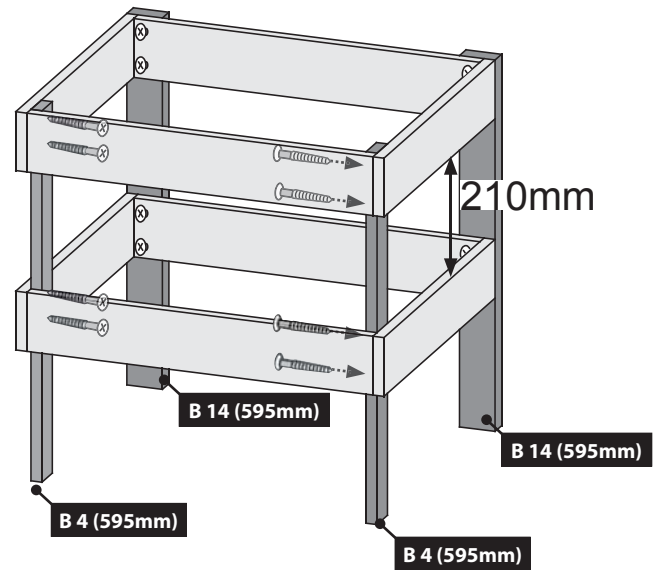

210mm

B 14 (595mm)

B 14 (595mm)

B 4 (595mm)

B 4 (595mm)

22 b

-  Bei allen anderen Öfen
-  Pour tous les autres fours
-  For all other furnaces
-  Voor alle andere ovens
-  Para todos los otros hornos
-  Per tutti gli altri tipi di forni
-  U všech ostatních pecích
-  Til alle andre ovne

Ø3 mm

16x

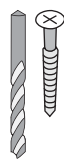

4x35

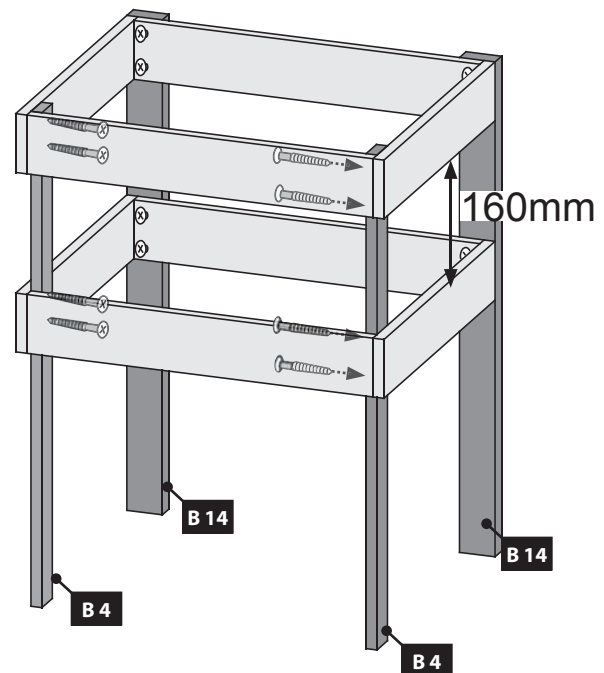

160mm

B 14

B 14

B 4

B 4

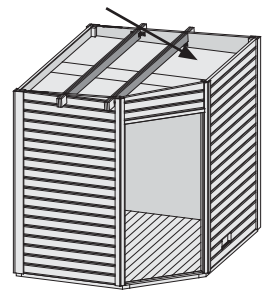
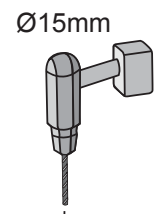
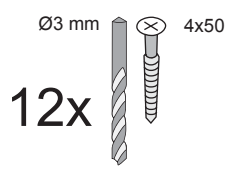
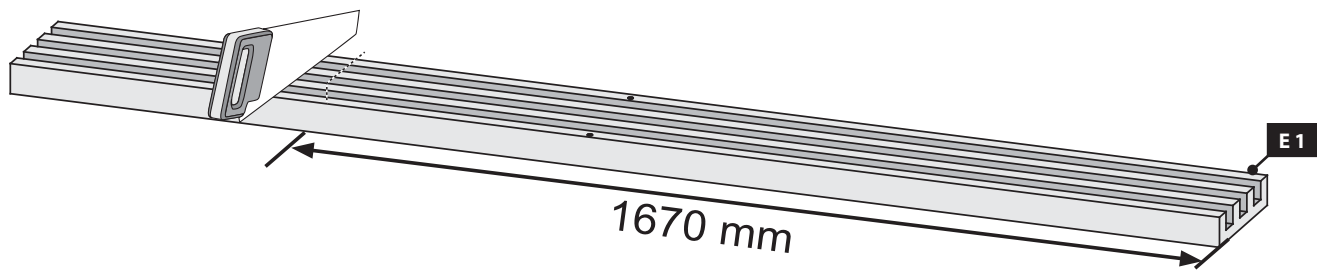

1.

2.

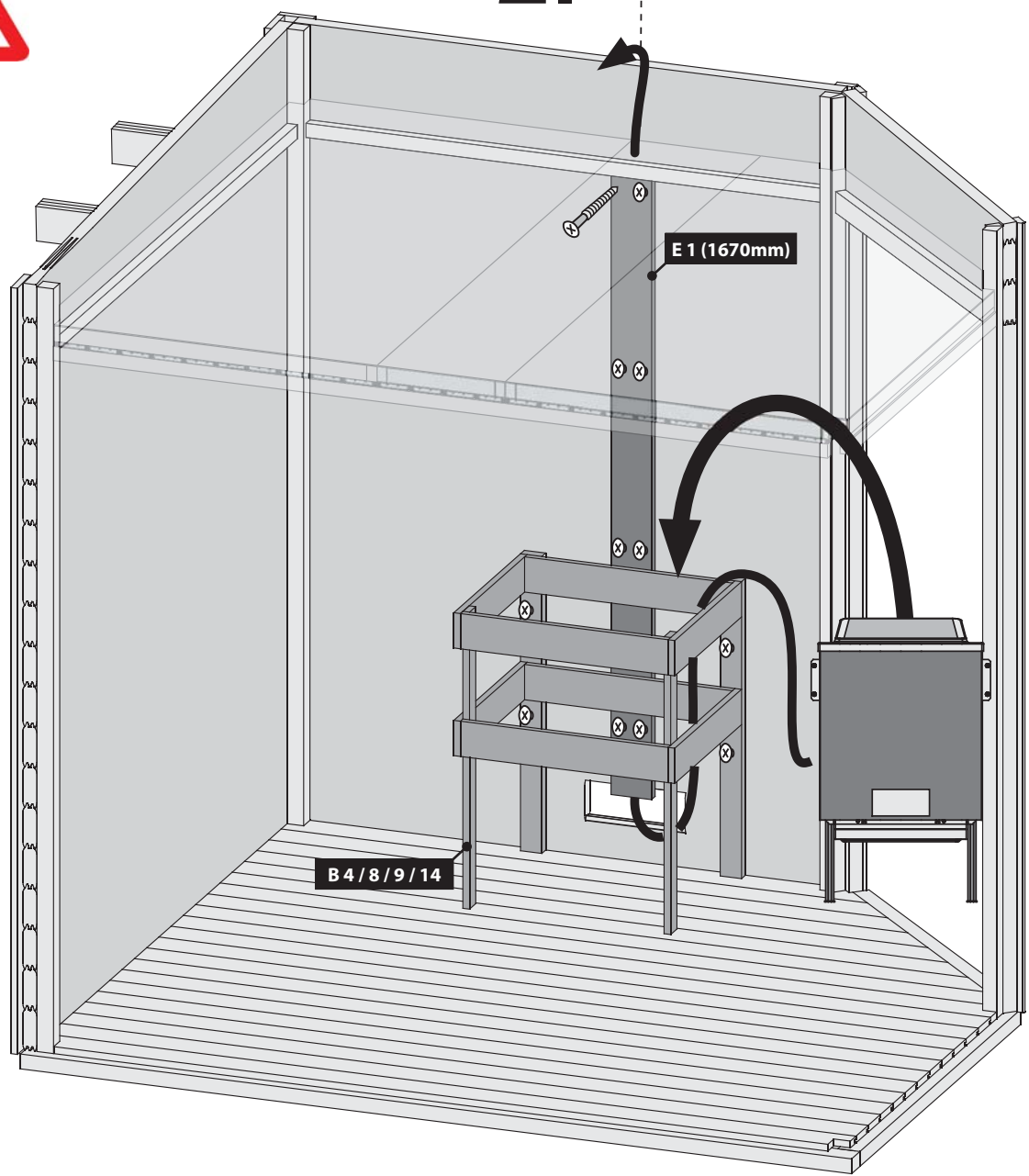

1.

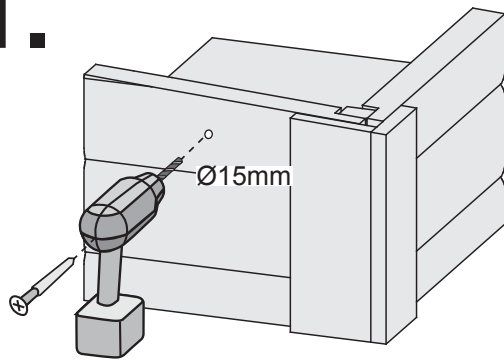

2.

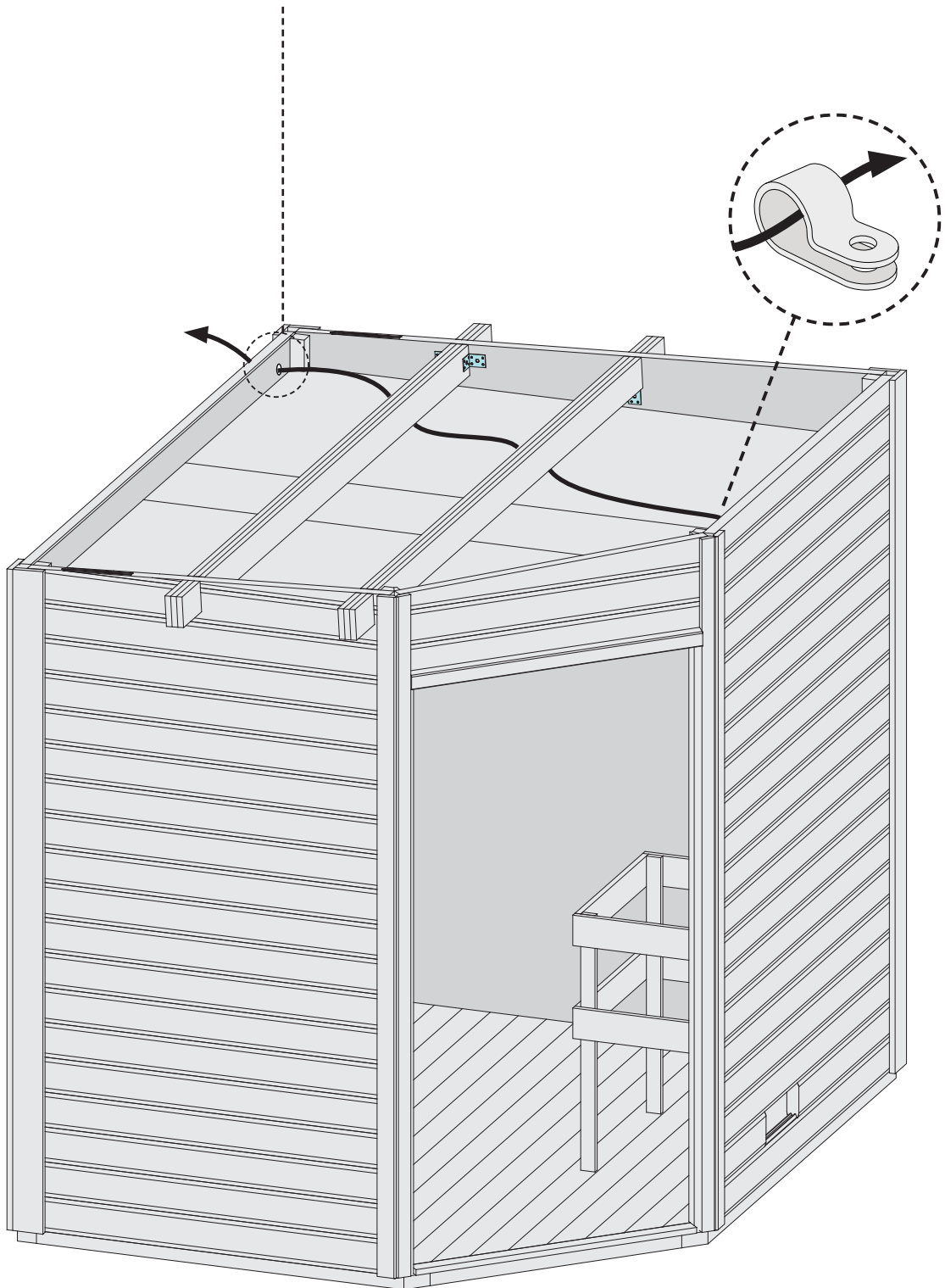
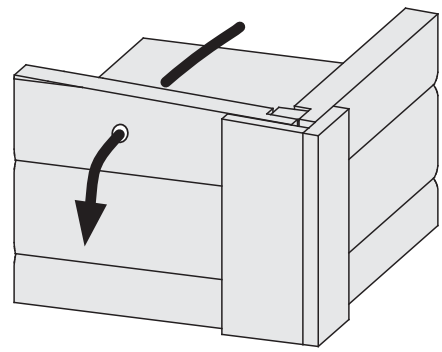

26

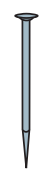

≈ 240x

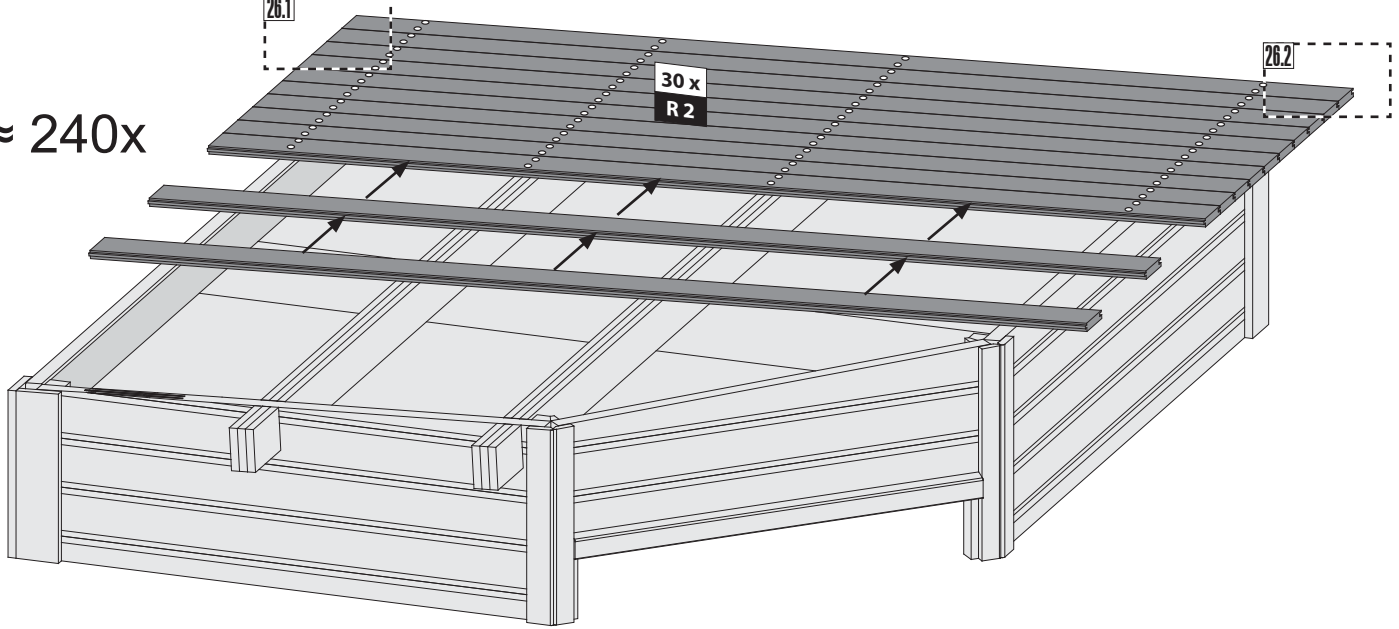

26.1

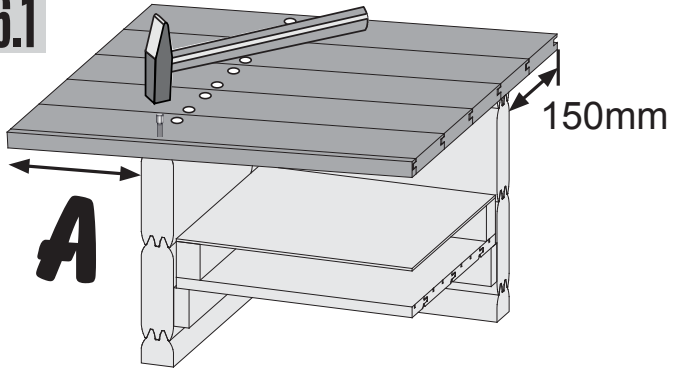

26.2

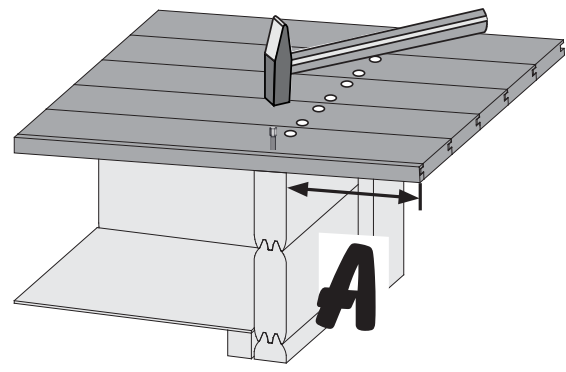

27

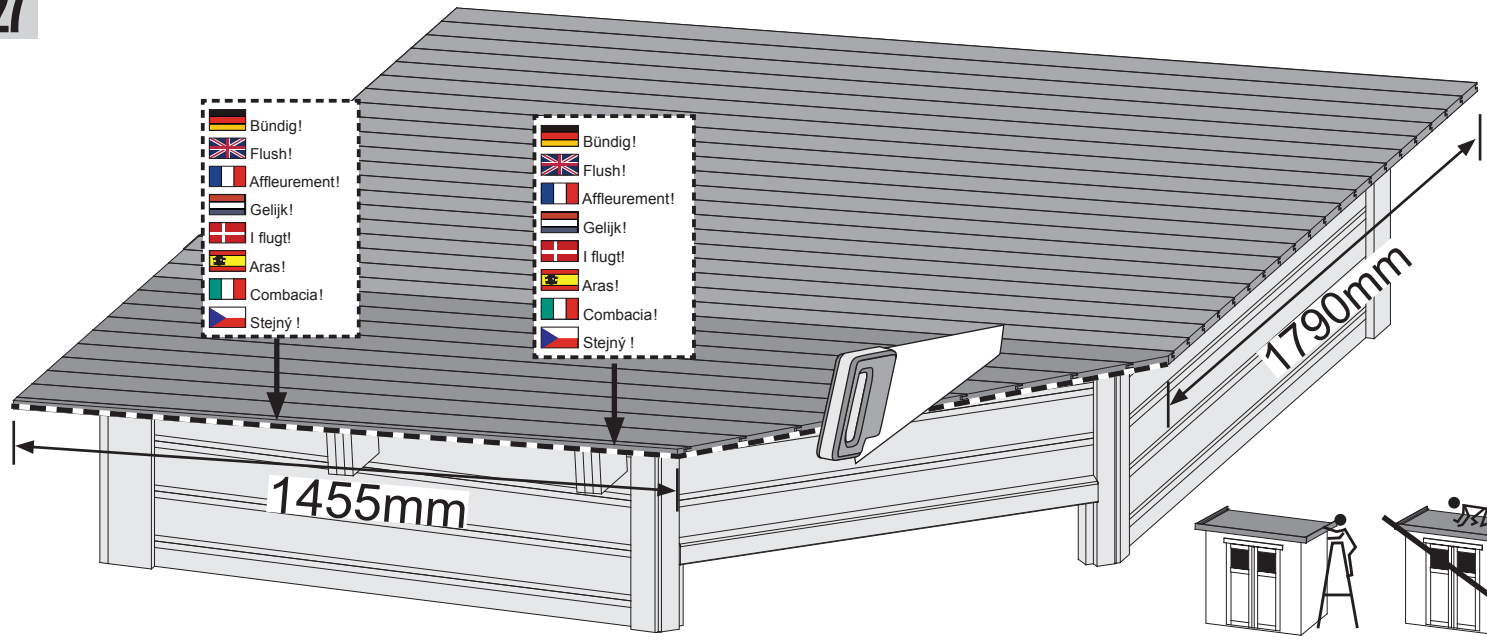

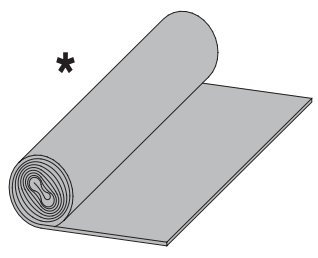
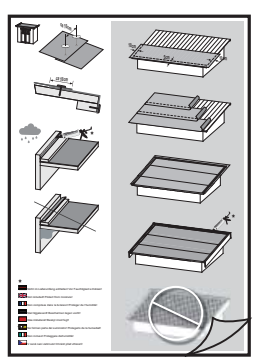
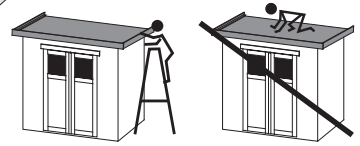

- Bündig!
- Flush!
- Affleurement!
- Gelijk!
- I flugt!
- Aras!
- Combacia!
- Stejný!

- Bündig!
- Flush!
- Affleurement!
- Gelijk!
- I flugt!
- Aras!
- Combacia!
- Stejný!



 Montage Bitumendachbelag

 Montage de toiture en bitume

 Montage bitumen underpap

 Copertura bituminosa

 Roofing felt installation

 Montage dakvilt

 Montaje de tela asfáltica

 montáž střešní krytiny

 Achtung, dies ist nur ein Verlegebeispiel!

Der Bitumendachbelag dient zur Ersteindeckung und sollte nach 2 Monaten durch ein eigenes Produkt ergänzt werden. Die Anzahl der Bahnen richten sich nach Ihrer Hausgröße. Verbindungen zwischen den Bahnen sind mit einer Überlappung von ca. 10 cm auszuführen. Das Dach ist nicht begehbar. Die Konstruktion ist für eine Gesamtbelastung (Schnee, Wind) und nicht für eine Punktbelastung ausgelegt. Zur Montage empfehlen wir eine bauseitige Abstützung des Daches von unten. Die Abdichtung der Dachflächen zu angrenzenden Bauteilen mit Bitumendichtmasse ist bauseits zu lösen! Sofern es sich um ein Haus mit Satteldach handelt, sollte bei der Verwendung von Dachschindeln keine Voreindeckung mit Dachpappe vorgenommen werden. Hier sollte lediglich an den beiden Traufseiten ein 20 cm breiter Streifen mit Überstand angebracht werden. Bei Häusern mit einem Tonnendach, verlegen Sie bitte einen Bitumenbelag unter die Schindeln. Bei einem Flachdach ist die Verlegung von Dachschindeln nicht möglich!

 Note! This description is only an example!

The bitumen roofing is used for initial cover and should be supplemented by a separate product according to customers choice after two months. The number of bitumen strips to be used depends on your actual house size. When joining rolls of roofing felt end to end, the overlap must be approximately 10cm. The roof is not safe to walk on. The roof is designed for a total load (snow, wind) and not for a point load. We recommend you to always support the roof from below during installation. The sealing of the roof surfaces to adjacent components with bitumen sealant has to be effected by the customer! If it is a saddle-roofed house, do not use roofing tiles for roofing. In this case, a 20 cm wide strip of bitumen with overhang should be installed on both sides of the eaves. For houses with a tonne roof, please install a bitumen roofing under the shingles. In the case of a flat roof the laying of roof shingles is not possible!

 Attention, il s'agit uniquement d'un exemple de pose!

La revêtement se comprend comme dotation initiale. Il est donc recommandé de le compléter par un produit de votre choix après 2 mois. Le nombre de bandes de bitume utilisés dépend de la dimension de la maison. La jointure des bandes de bitume doit être réalisée avec un chevauchement de 10 cm. Ne pas marcher sur le toit! La construction est appropriée pour une charge totale (neige, vent) et ne pas une charge ponctuelle sur un point précis. Lors du montage, il vous est recommandé de soutenir le toit d'en dessous. L'imperméabilisation des surfaces de toit aux composants adjacents avec un mastic de bitume doit être effectuée par le client! Lorsque vous utilisez des bardeaux pour couvrir une maison avec un toit à deux versants, ne jamais utiliser toiture en bitume ci-dessous. Pour les maisons avec toit en berceau, poser du carton bitumé sous les bardeaux. Pour les maisons de toit plat de la pose de bardeaux de toiture n'est pas possible!

 Let op, dit is slechts een montagevoorbeeld!

De bitumen dakbedekking wordt gebruikt voor initiële en moet worden aangevuld met een afzonderlijke product na 2 maanden. Het aantal dakviltbanen is afhankelijk van de grootte van uw huis. Verbindingen tussen de stroken uit te voeren met een overlapping van ongeveer 10 cm. Het dak is niet beloopbaar. De constructie is ontworpen voor een totaalbelasting (sneeuw, wind) en niet voor een puntbelasting. Voor de montage adviseren we te voorzien in een zelf aan te brengen steun voor het dak van onderen. De afdichting van de dakoppervlakken van aangrenzende componenten met bitumen afdichtmiddel op te lossen door de klant! Als het gaat om huis met een zadeldak, mag geen Voreindeckung worden gemaakt met dakleer in het gebruik van dakbedekking gordelroos. Hier, moet alleen de twee dakrand zijden een 20cm brede strook dakleer aan te leggen met een overstek. Voor huizen met een dak vat installeer dan een dakleer onder de gordelroos. Met een plat dak leggen shingles is niet mogelijk!

 Bemærk, dette er kun et monteringsksempel!

Den inddækning tjener kun til midlertidig inddækning og skal senest efter 2 måneder erstattes med et hertil egnet produkt. Antallet af påkrævede ruller af tagbeklædning afhænger af husets faktiske størrelse. Ved sammenføjning af tagdækning ruller ende til ende, skal overlappningen være 10 cm. Når du kun bruger 4 baner af tagpap, skal du altid dække den vandrette kantbjælke med rullerne fra begge sider. Taget er ikke sikkert at gå på. Taget er designet til en total belastning (sne, vind) og ikke for en punktbelastning. Vi anbefaler at du altid støtter taget nedenunder under installationen. Tætningen af tagfladerne til vindbrættet i forenderne skal løses af kunden! Når du bruger tagshingles til at inddække et hus med gavtag, skal du altid bruge underpap tagbeklædningen. Her lægges et 20 cm bredt bånd af tagbeklædning med overlæg på begge sider. Monter altid underpap tagbeklædningen under tagshingles til huse med et buet tag. Ved fladt tag kan tagshingles ikke anvendes!

 Cuidado, éste es sólo un ejemplo de instalación!

La cubierta de betún se utiliza para inicial y debe complementarse con un producto separado después de 2 meses. La cantidad de tiras de tela asfáltica depende del tamaño de su caseta. Las juntas de tela en una tira se realizan solapando la tela asfáltica 10 cm. El techo no es transitable. La construcción está preparada para cargas totales (nieve, viento) y no para cargas puntuales. Para el montaje se recomienda apuntalar el techo por debajo. A menos que haya una casa de techo a dos aguas, sin Voreindeckung debe hacerse con tela asfáltica en el uso de tejas para techos. En este caso, sólo los dos aleros partes deben ser de una amplia franja de 20 cm de tela asfáltica que deben colocarse con un voladizo. Para las casas con el techo abovedado y por favor, instale un techo sintió debajo de las tejas. Con un techo plano por el que las tejas no es posible!

 Attenzione, questo è solo un esempio di posa!

La copertura bitume è utilizzato per iniziale e deve essere completato da un prodotto separato dopo 2 mesi. La quantità dei rulli di cartone catramato dipende dalle dimensioni della casa. Il concatenamento tra i nastri deve essere effettuata con una sovrapposizione di circa 10 cm. Non salire sul tetto. La costruzione è progettata per un carico diffuso (neve, vento) e non per una concentrazione puntuale del peso. Per il montaggio si consiglia un supporto del tetto con una costruzione posta sotto di esso. Se si dispone di una casa con un tetto a capanna e si desidera utilizzare tegole di copertura, deve essere posato senza fogli di bitume. Qui, un largo 20 cm striscia di bitume deve essere montato esclusivamente ad entrambi i lati della grondaia sporgente 20 cm. Per le case con fogli di bitume per tetti a botte sotto il fuoco di Sant'Antonio da installare. Si prega di non utilizzare il fuoco di Sant'Antonio Dackdeckung con un tetto piatto.

 **Pozor, toto je jen příklad, kterým!**

Bitumen se používá pro počáteční a by měl být doplněn samostatný produkt po 2 měsících.

Počet Dachpappbahnen závisí na velikosti domu. Spojení mezi asfaltem pásu má být provedena s přesahem asi 10 cm. Při použití pouze čtyři běhy ne Firstbahn použití, boční panely s ležel přes hřeben. Střecha není přístupný. Konstrukce je (sníh, vítr) a není určen pro bodové zatížení na celkové zatížení. Pro montáž doporučujeme znovu podporu na místě střechy zespodu. Utěsnění střešních oblastí do podhledů na čelních plochách je na místě řešit! Máte-li dům se sedlovou střechou, je třeba žádné Asfaltové pásy umístěny pod šindele. Zde je 20 cm široký pás střešní plst' je pouze na obou stranách okapového se supernatantem odloženou. Pro rodinné domy s valenou střechou prosím ležel lepenkový pod šindelem. Pro ploché střechy domů pokládka střešních šindelů není možné!

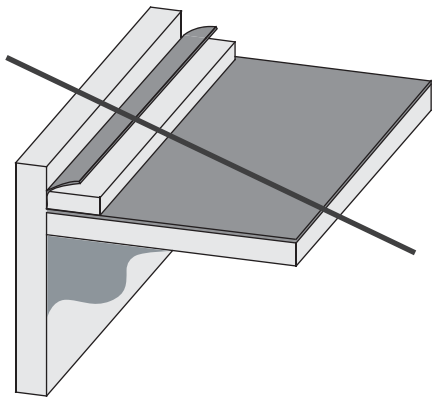
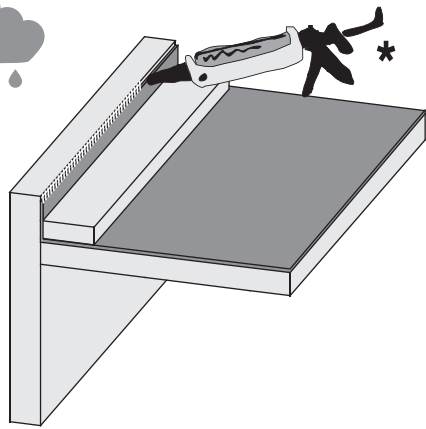
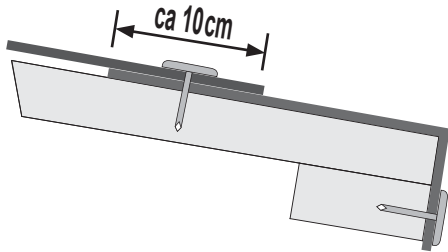
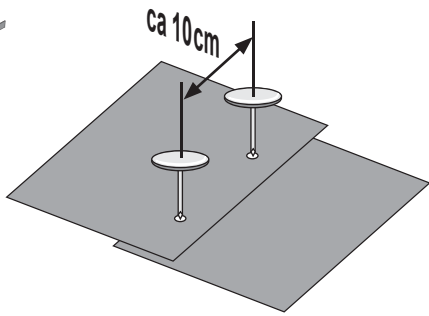
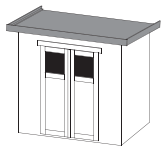



*

 Nicht im Lieferumfang enthalten! Vor Feuchtigkeit schützen!

 Not included! Protect from moisture!

 Non comprises dans la livraison! Protéger de l'humidité!

 Niet bijgeleverd! Beschermen tegen vocht!

 Ikke inkluderet! Beskyt imod fugt!

 No forman parte del suministro! Protegerlo de la humedad!

 Non incluso! Proteggere dall'umidità!

 V ceně není zahrnuto! Chránit před vlhkostí!

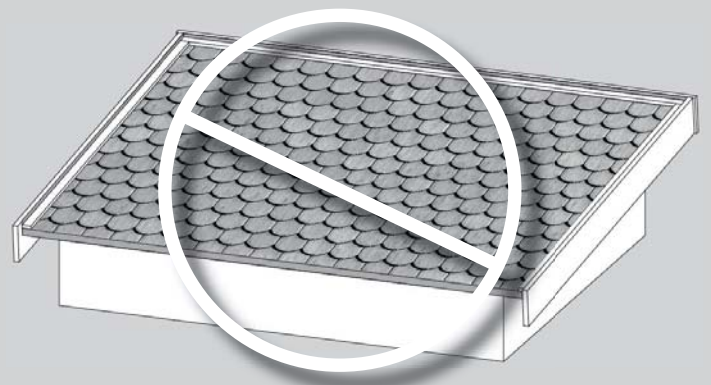
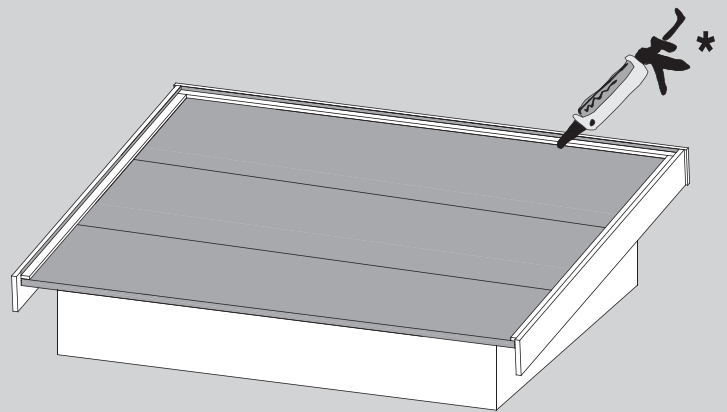
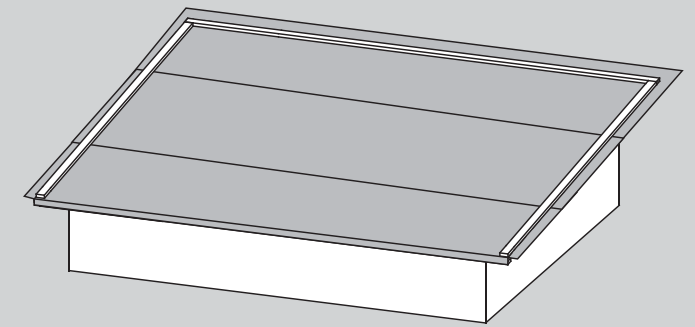
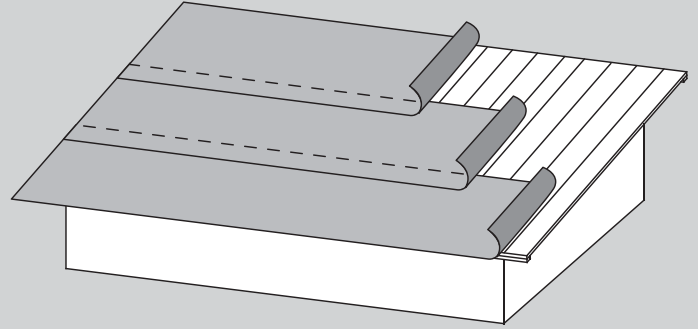
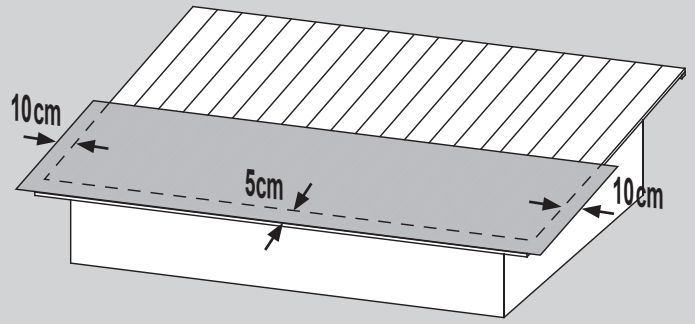

28

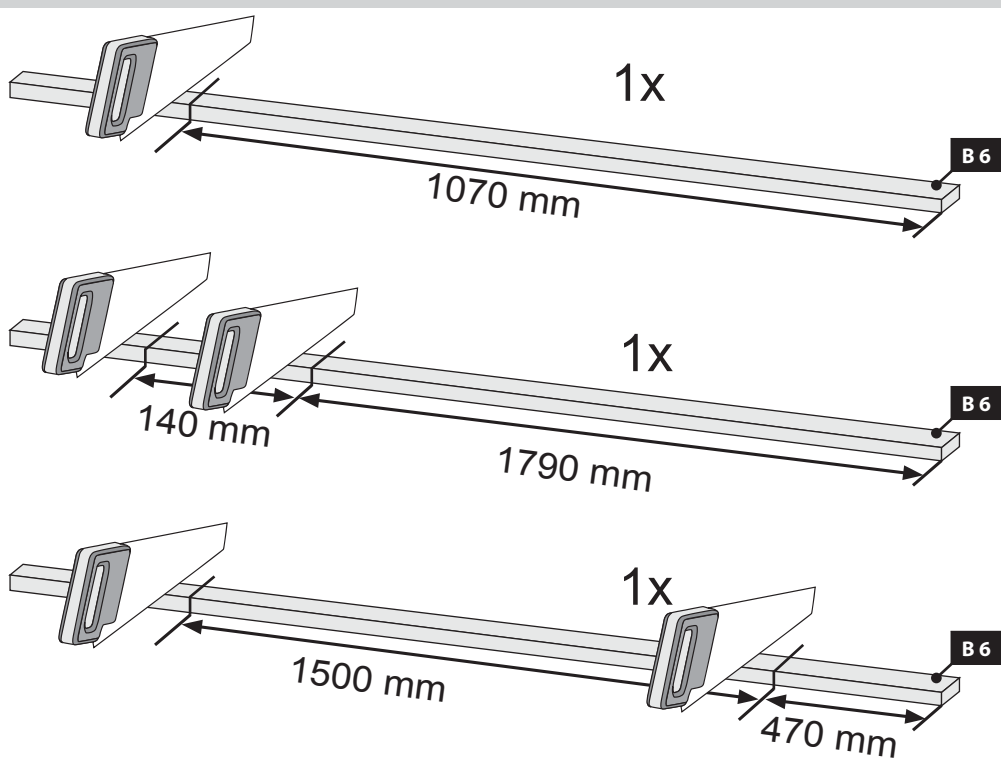

29

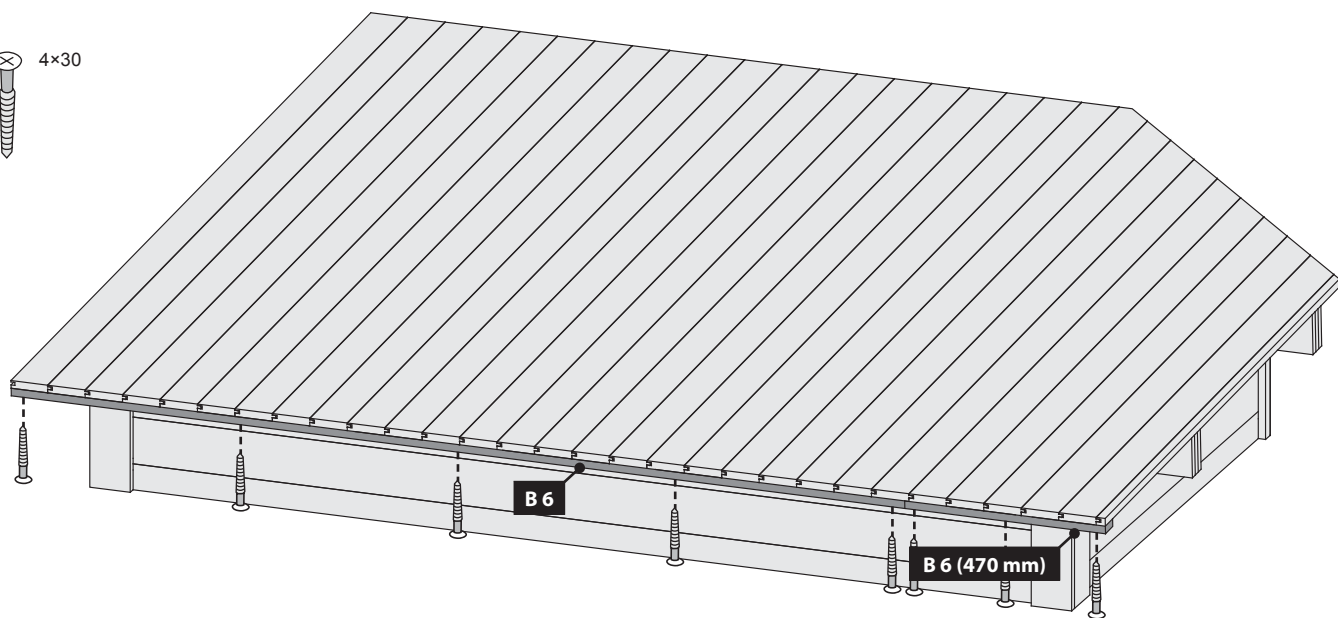
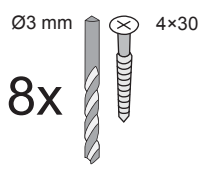

30

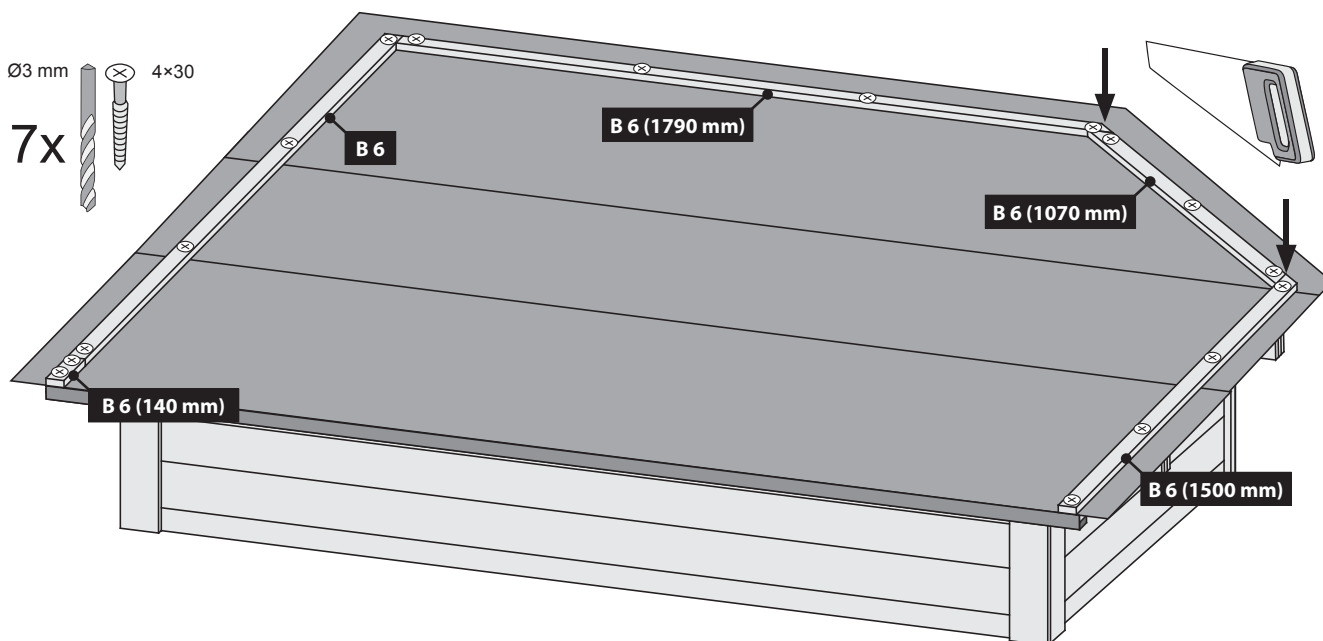
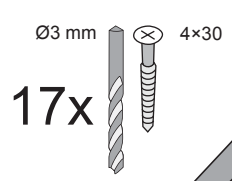

31

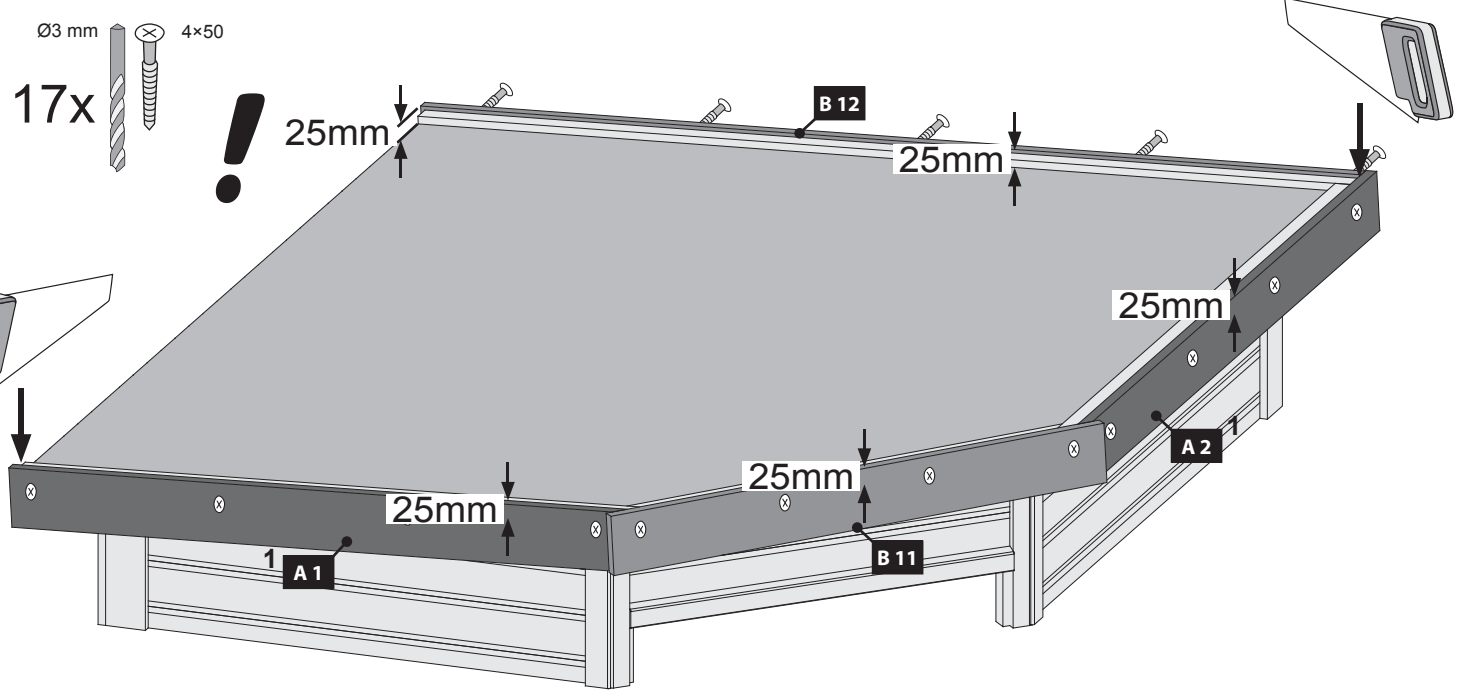

32

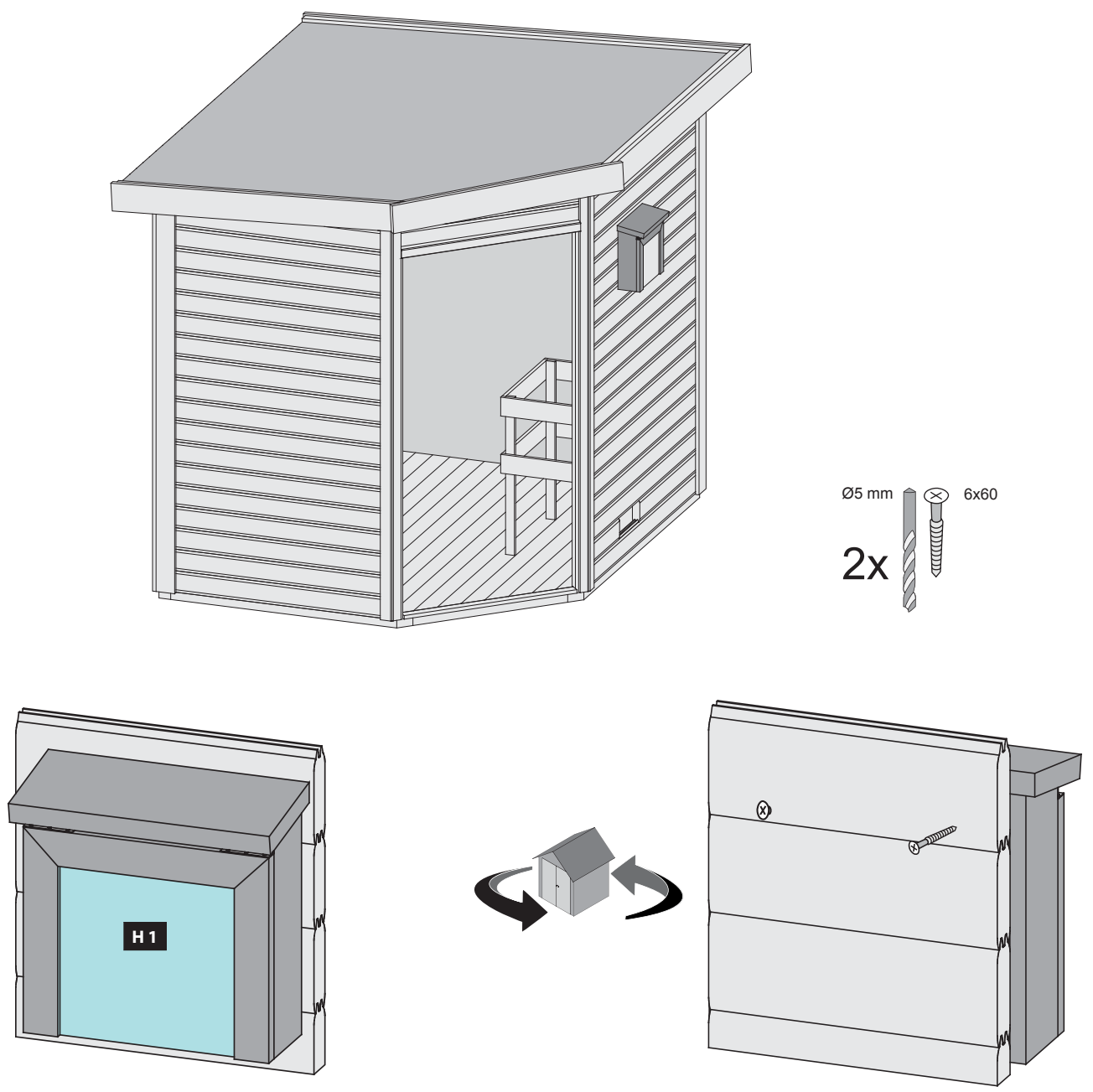

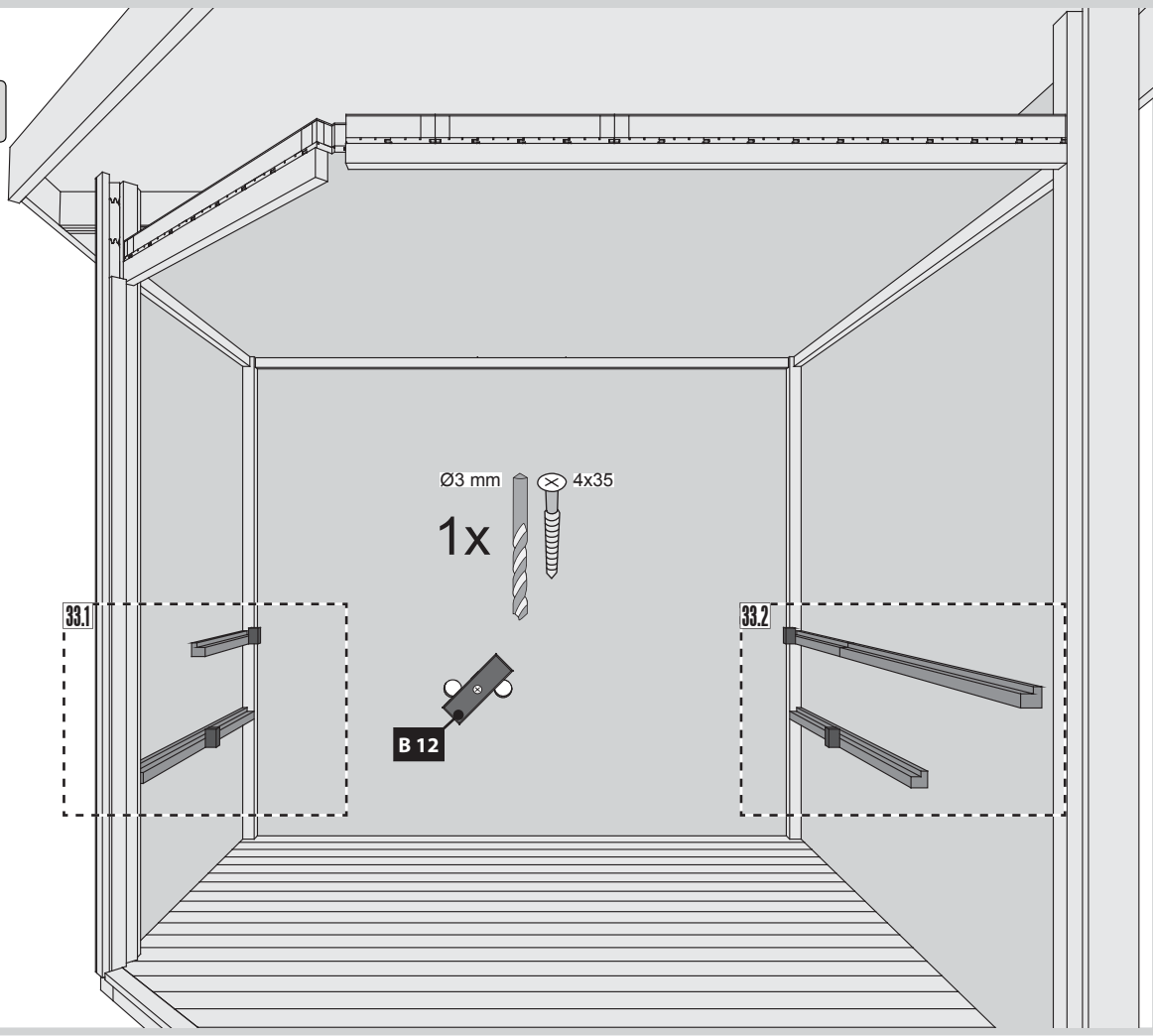

-  Ansicht innen
-  View Inside
-  Voir à l'intérieur
-  Bekijk binnen
-  Ver dentro
-  Visualizza dentro
-  Zobrazit uvnitř
-  Se inde

33.1

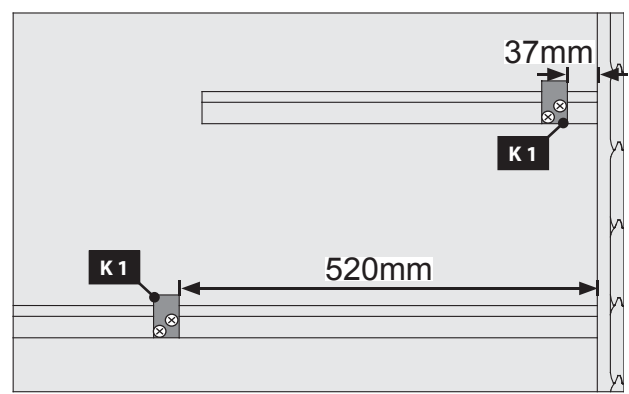
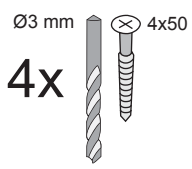
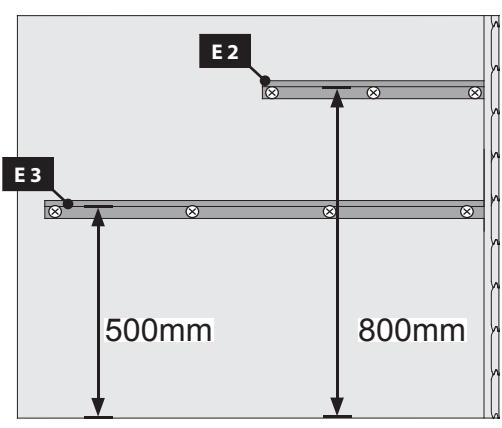
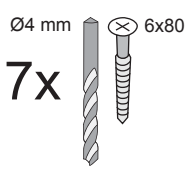

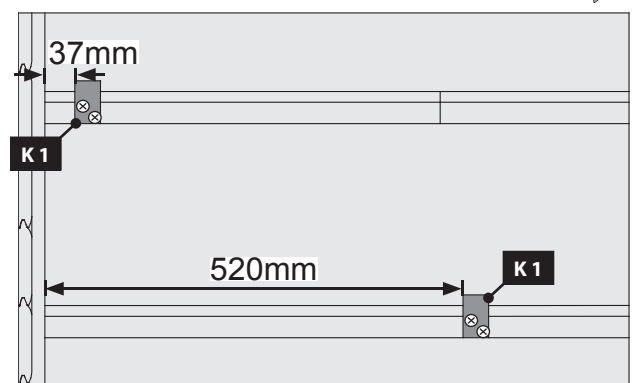
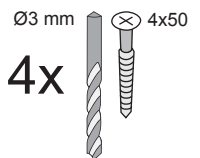
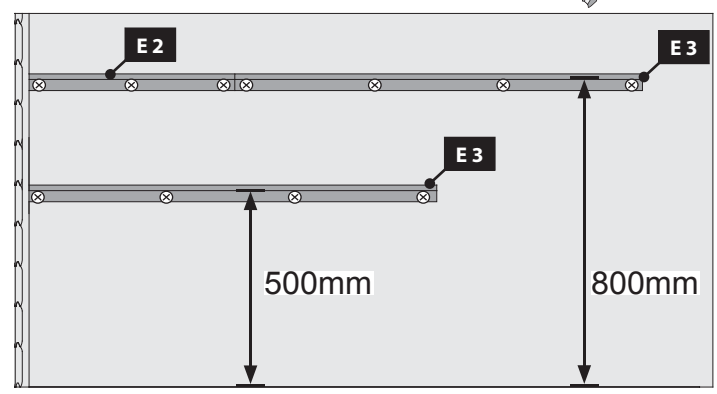
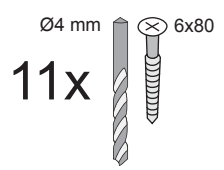

33.2

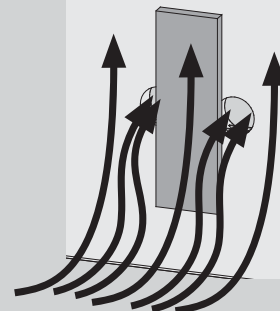
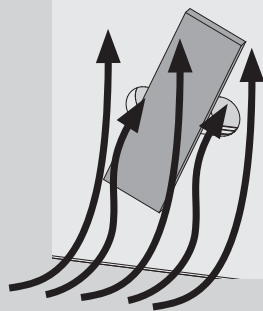
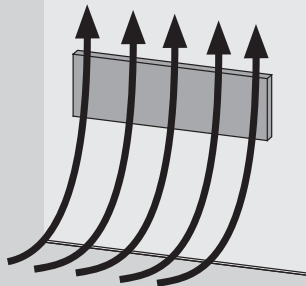
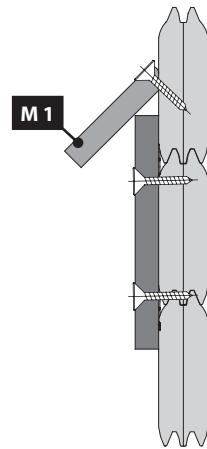
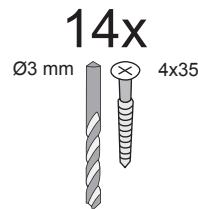
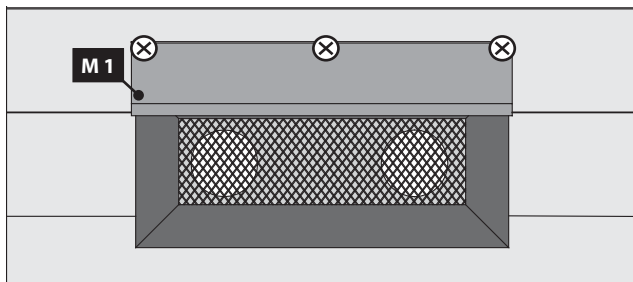
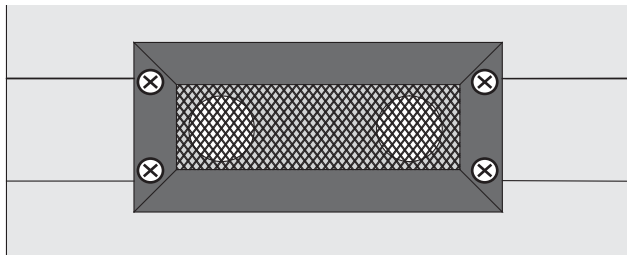
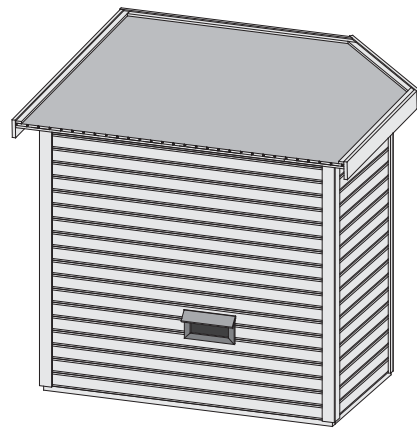
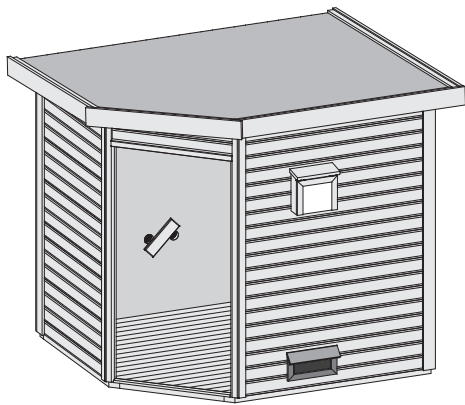





 Hier ist die Funktionsweise des Brettes abgebildet. Regeln Sie damit die Abluft nach Ihren eigenen Wünschen.

 Ceci représente le mode de fonctionnement de la planche. Avec elle, réglez l'écoulement de l'air selon vos désirs.

 This figure shows the functional principle of the board. Regulate the exhaust air according to your own wishes.

 Hier is de werking van het plankje afgebeeld. Regel daarmee de luchtafvoer naar eigen wens.

 Aquí está representada la forma de funcionamiento de la tabla. Regule con ello el aire de salida según sus propios deseos.

 Viene illustrato il principio di funzionamento della tavoletta di regolazione della ventilazione. Con essa si può regolare a piacere la ventilazione.

 Zde je zobrazená funkce desky. Regulujte s ní odsávací vzduch dle Vašeho přání.

 Sådan fungerer styret. Brug den til at regulere udstødningsluften efter dine egne ønsker.

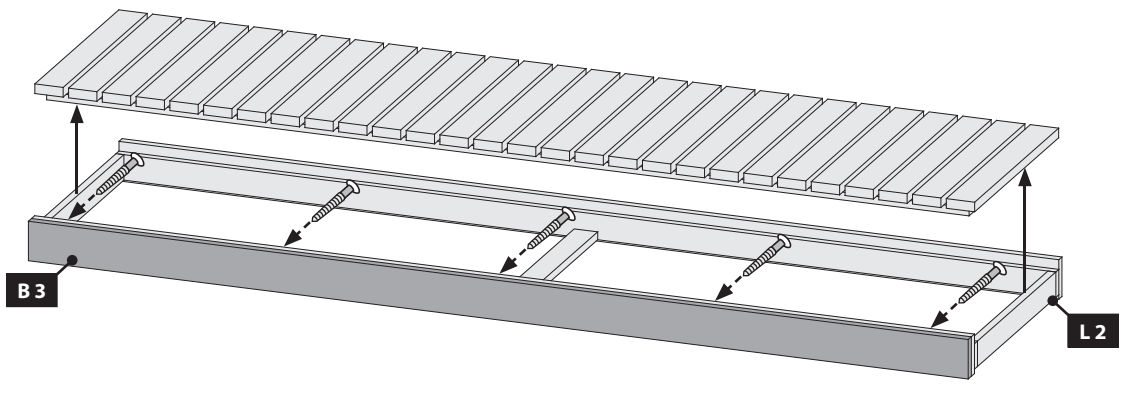

Ø3 mm 4x50
5x

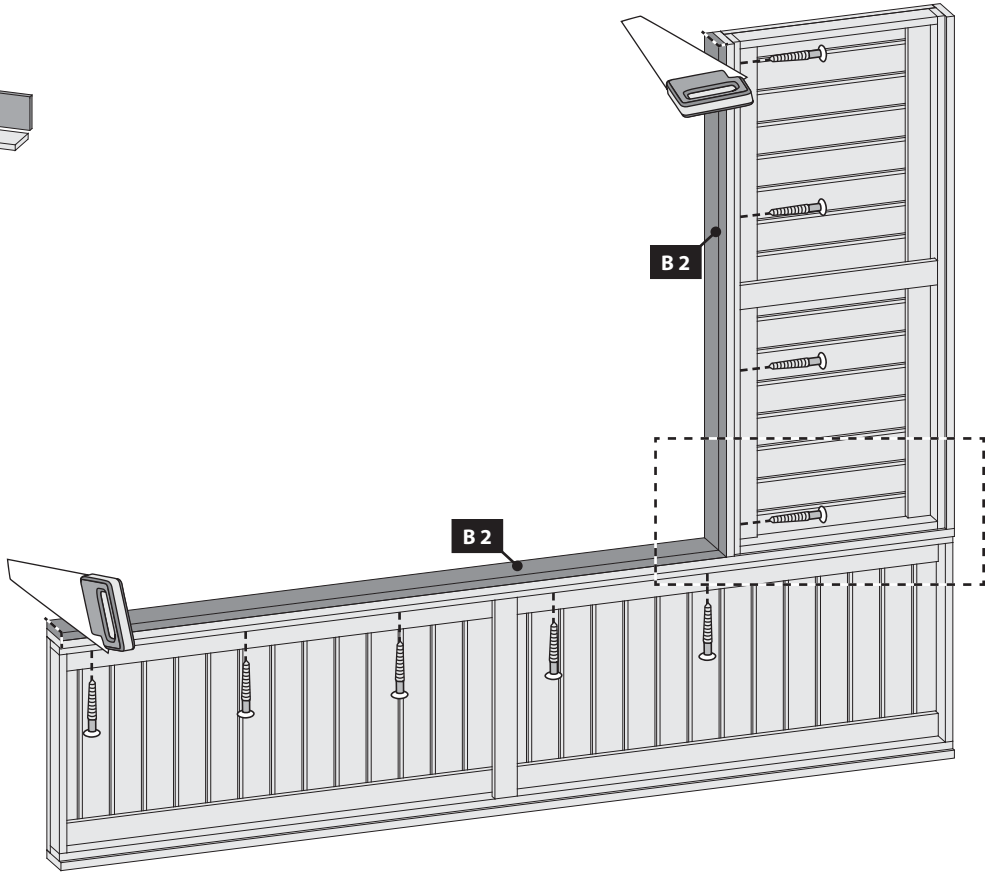
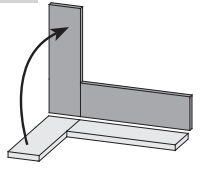
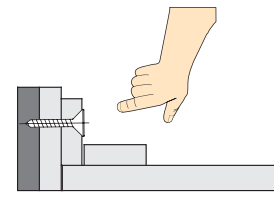

Ø3 mm 4x50
9x

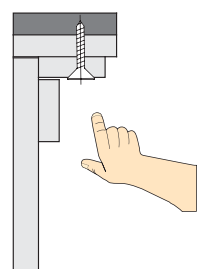

2x
16x

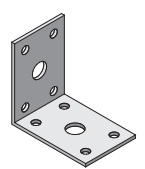

Ø3 mm 4x35

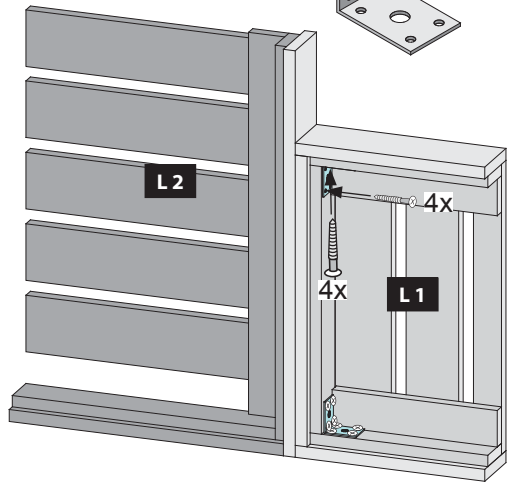

Ø8 mm 4x50
3x

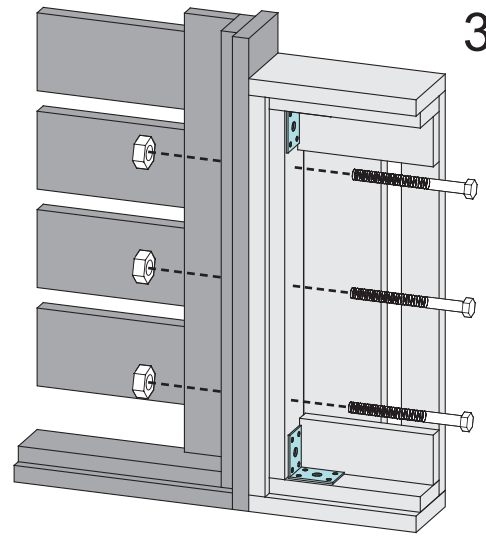

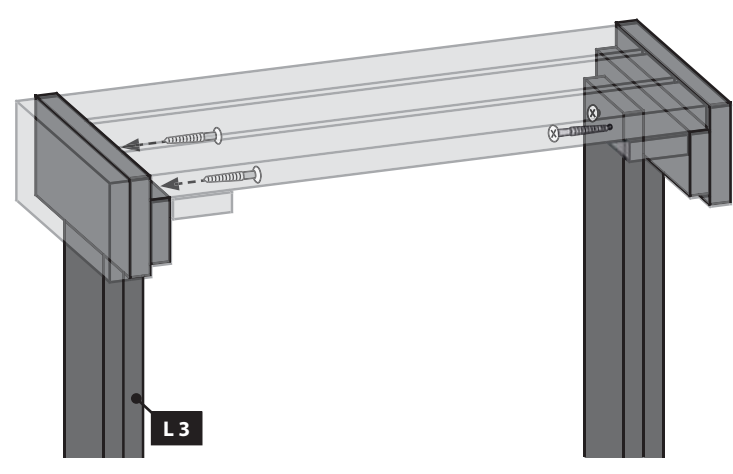
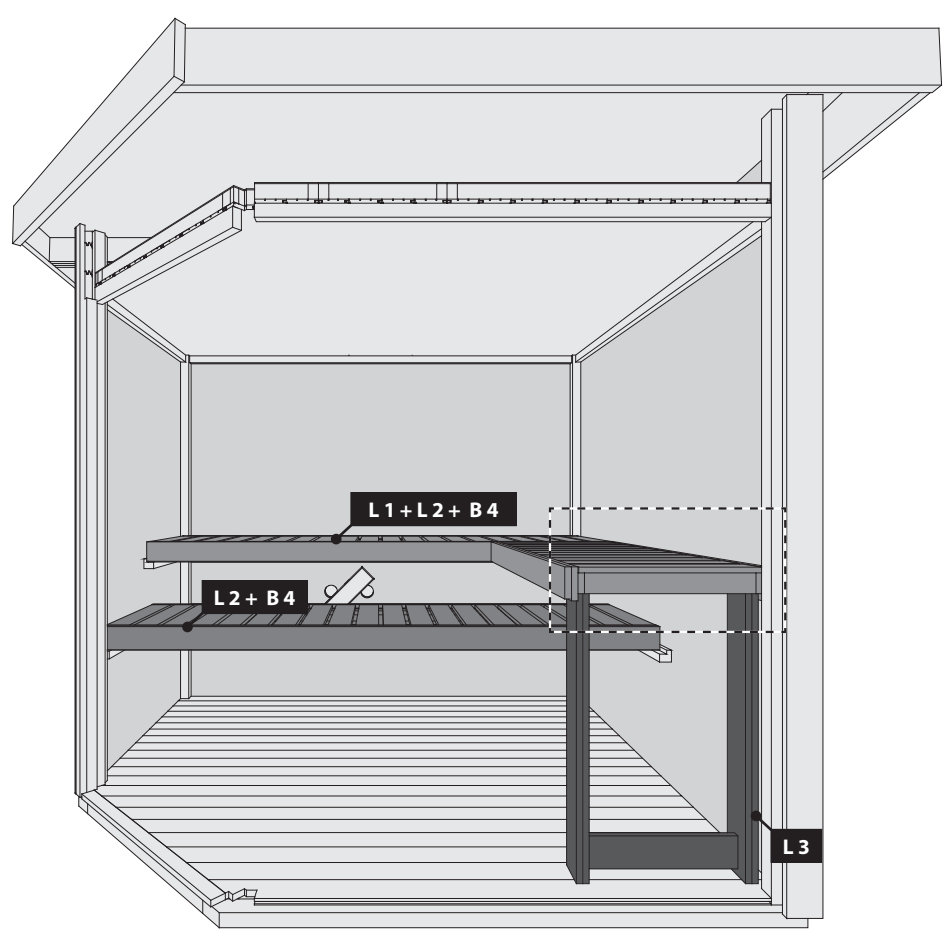

Ø3 mm 4x35
4x

-  Ofenbefestigung
-  oven vaststelling
-  oven fixing
-  fixation four
-  fijación horno
-  fissaggio forno
-  upevňovací trouba
-  ovn fastsættelse

